

2CV FUEL GAUGE AND BATTERY METER

Revision 3



Some glorious New Zealand scenery during Raid 2018

By Graeme Dennes

2CV FUEL GAUGE AND BATTERY METER

Revision 3

By Graeme Dennes

Introduction:

The writer's 1974 2CV incorporates a fuel gauge and a battery meter (a.k.a. voltmeter or battery charge meter) within the speedometer assembly, per Photo 1 below. This article explores the basis of operation of these two instruments and shows how they connect to and interact with the vehicle's electrical system. (The writer's 1987 2CV has the squarer speedometer which doesn't include a battery meter.)

As an added benefit, the battery meter will be calibrated to make its coloured scale more useful in terms of practical voltage points on the scale, enabling the battery status and the alternator/regulator performance to be readily monitored.



Photo 1. The writer's 1974 2CV speedometer assembly showing the fuel gauge at lower left and the battery meter at lower right.

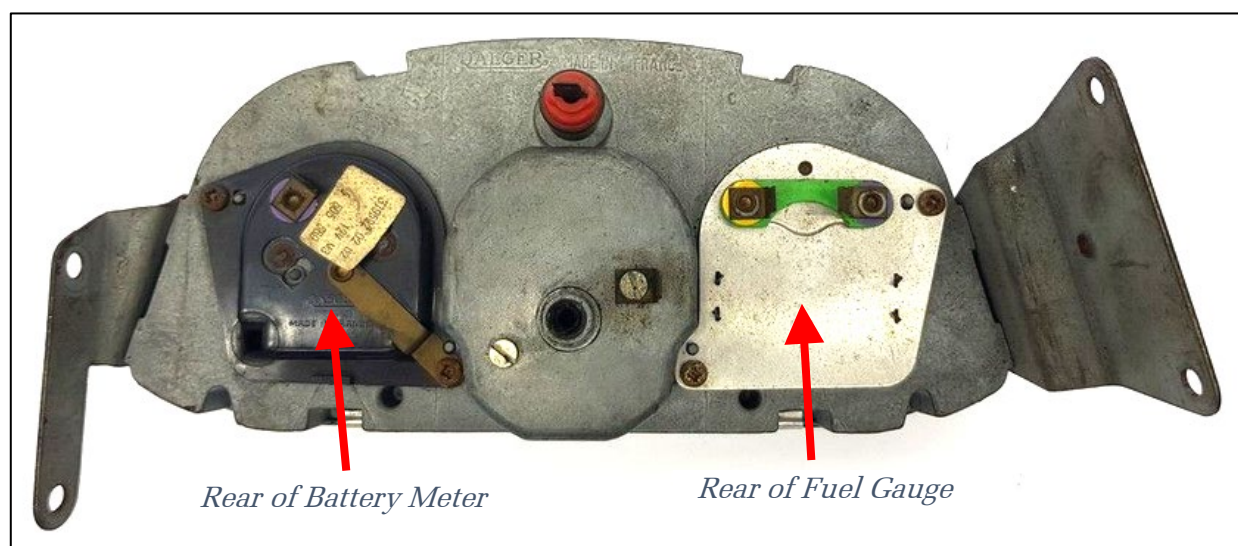

Photo 2. Rear of the speedometer assembly after its removal from the vehicle.

2CV Fuel Gauge:

At the heart of the 2CV fuel gauge is a dual-coil moving iron meter, an early type of electrical measuring instrument. The moving iron fuel gauge was popular with automobile manufacturers up to at least the 1960s, with some vehicles using them into the 1970s, after which it essentially disappeared, well, except from the 2CV. The moving iron fuel gauge remained the standard issue fuel gauge for the 2CV up to the very last vehicle leaving the production line in Portugal on 27 July 1990.

A moving iron meter operates by electrical current supplied by the vehicle's battery. The needle (pointer) deflection is proportional to the *relative difference* in the strengths of the magnetic fields generated by two offset coils. By means of this arrangement, the moving iron meter is almost impervious to changes in battery voltage, being that the magnetic field strengths of the coils are simultaneously affected in proportion to the battery voltage. Another of the moving iron meter's characteristics is that its needle immediately returns to its resting position when the ignition switch is turned off, when the magnetic fields from the coils are no longer present.

Treat the fuel gauge and the battery meter with kid gloves. The moving parts are extremely delicate and light weight and can be *very* easily damaged.

The writer removed the fuel gauge and battery meter from a spare speedometer assembly and took some photos and electrical measurements of the internal components. We'll consider the fuel gauge first.

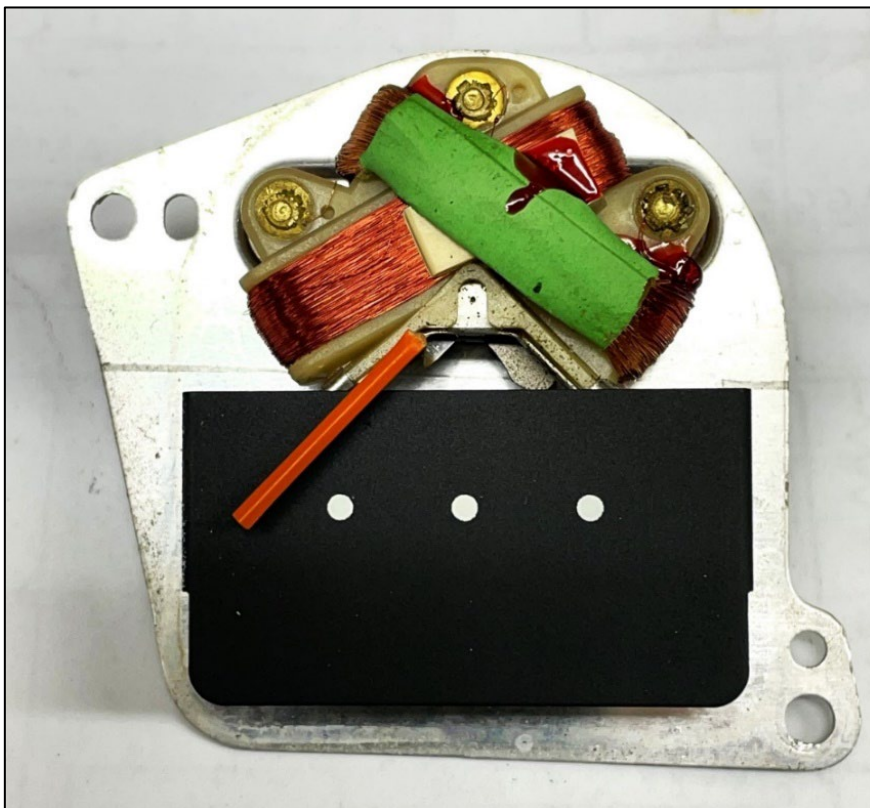

Photo 3. 2CV fuel gauge exposed, with the needle at its resting (ignition off) position.

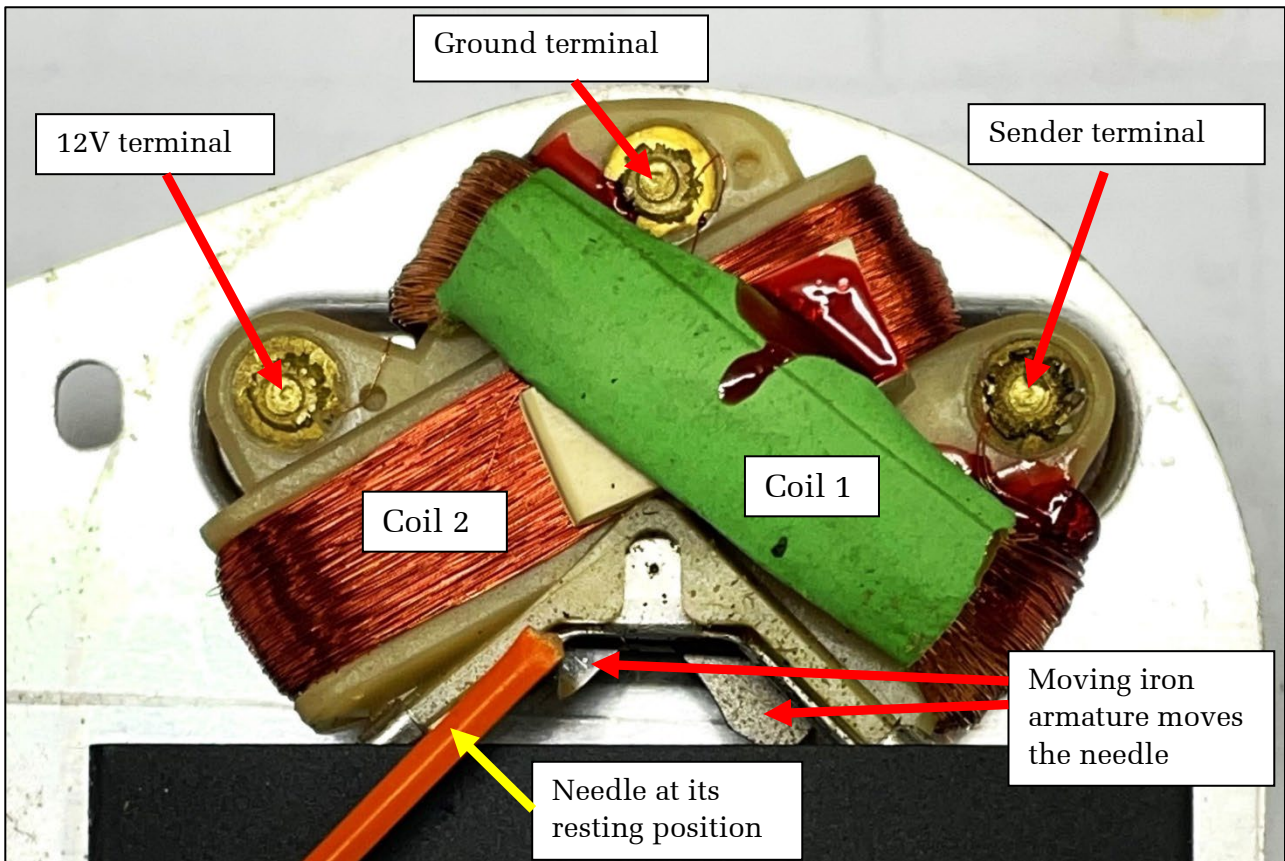

Photo 4. 'Allo,'Allo, what is zis?

The fuel gauge has three electrical connections, shown in Photo 4 above. The 12V terminal connects to the battery via the ignition switch, the Ground terminal connects to chassis ground, and the Sender terminal connects to the fuel tank sender unit. (The other connection from the sender unit connects to chassis ground adjacent to the tank.)

The currents in the two coils set the position of the moving iron armature according to the *relative difference* in the coils' magnetic field strengths. What does this mean? If the battery voltage was increased by say 50 percent, the magnetic field strengths of both coils would increase by 50 percent, maintaining a constant relative difference between them, thus keeping the armature (and the needle) in the same position. The needle is attached to the moving iron armature. The sender unit's resistance controls the currents flowing through the two coils, and hence the position of the armature and the needle.

The moving iron meter, as used for the 2CV fuel gauge, responds to the resistance of the fuel tank's sender unit for its operation. This also means it responds to *momentary* changes in the sender unit's resistance. Thus, when travelling on a rough road, when the fuel sender's float height is constantly changing due to fuel motion within the tank, the momentary changes in the sender unit's resistance results in momentary changes (deflections/flickers) of the fuel gauge needle as the gauge attempts to respond to the sender unit's (changing) resistance. This is an irritating bi-product of the moving iron fuel gauge's operation. The moving iron meter is known as an under-damped meter in control system theory.

2CV Fuel Gauge Circuit Diagram:

In Fig. 1 below, the two coils, Coil 1 and Coil 2, and the three connection terminals marked 12V, Sender and Ground, form the fuel gauge circuit. The 12V terminal connects to the battery via the ignition switch, the Sender terminal connects to the fuel tank sender unit (variable resistance), and the Ground terminal connects to chassis ground. As already noted, the ground connection of the sender unit connects to chassis ground near the fuel tank.

Further to Photo 4, in the writer's spare fuel gauge, Coil 1 has a resistance of 137 ohms and Coil 2 has a resistance of 407 ohms. The turns of wire on each coil is not known but the diameters of the enamelled copper wire used for the two coils appear to be identical.

The writer's 2CV fuel tank sender unit shows a "Full" resistance of approx. 10 ohms and an "Empty" resistance of approx. 330 ohms. The change in resistance of the sender unit changes the currents flowing in the two coils, which changes the position of the moving iron armature and thus the position of the needle on the scale.

The resistances measured for the fuel gauge coils and the fuel tank sender unit are likely to be nominal values only. An expected range of $\pm 5\%$ about these figures would seem feasible.

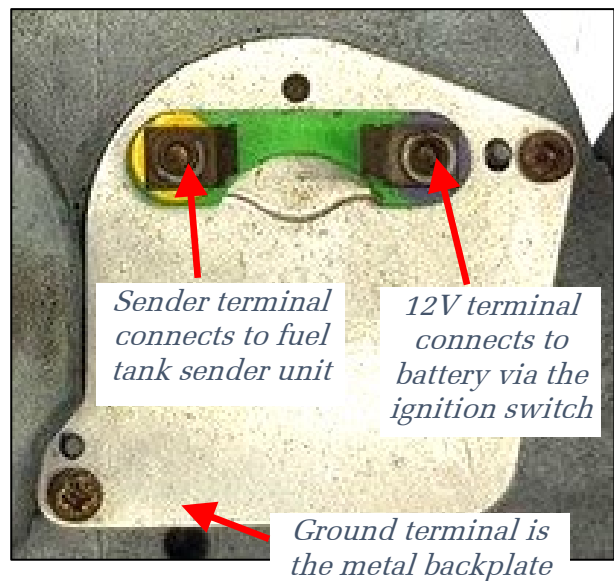
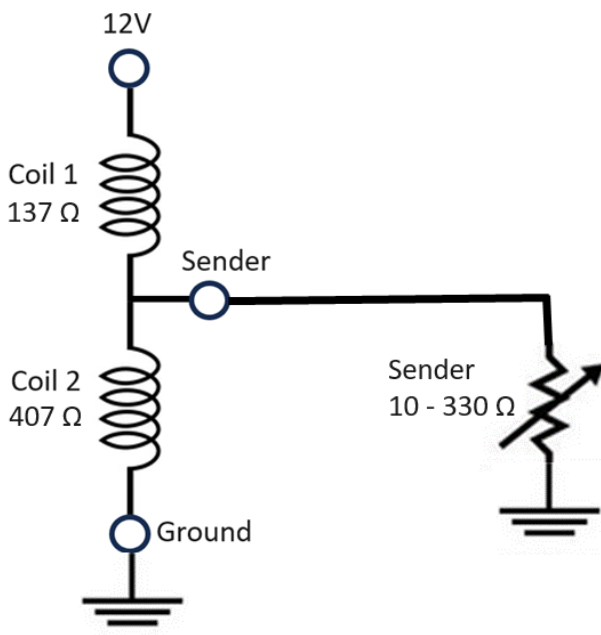

Photo 5. The ground terminal is the back plate of the fuel gauge.

Fig. 1. Internal circuit of fuel gauge.

Diagnostics:

From Fig. 1, for diagnostic purposes, the two coils are in series and the sender unit's resistance is in parallel with Coil 2. When the ignition is switched on and the sender unit is disconnected, the voltage at the Sender terminal of the gauge will be around 9V, i.e., $407 / (137 + 407) \times 12V$.

Fuel Gauge Internal Wiring:

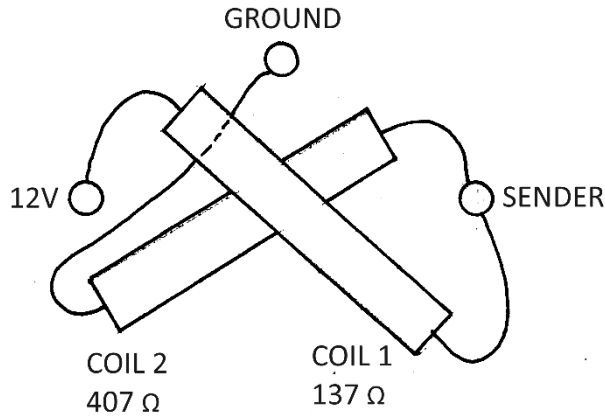

Fig. 2. Internal wiring and coil layout of fuel gauge. Compare with Photo 4.

Basic construction of the 2CV Fuel Gauge:

Fig. 3 below shows the basic construction of the dual-coil moving iron fuel gauge, except that the two coils are shown separated for clarity and understanding.

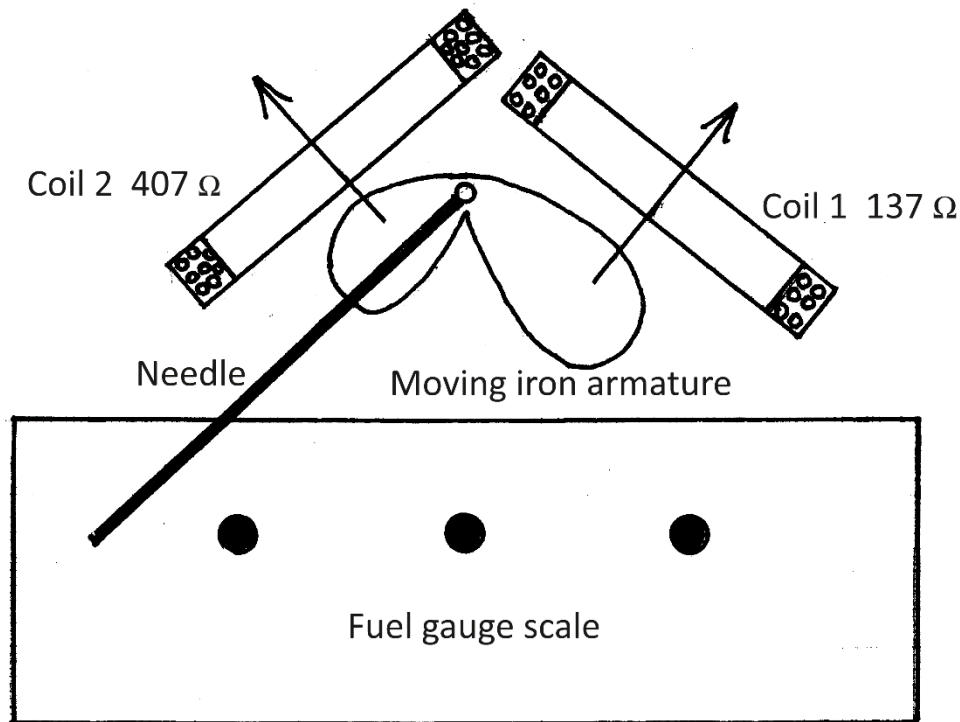

Fig. 3. In-principle construction of the fuel gauge.

The moving iron armature is formed by two very lightweight, wafer-thin flat soft-iron lobes approximated in Fig. 3, pivoted between two mounting supports. Because of the asymmetrical shape of the lobes, where the right-side lobe is larger than the left-side lobe, when the ignition is switched off, the heavier right lobe drops downwards, rotating the lobes and needle clockwise about the pivots, taking the needle to the very left end of its travel, i.e., to its resting position, as shown in Photos 3 and 4 and Fig. 3. The needle is shown attached to the armature in Fig. 3.

Fuel Gauge Operation:

When the ignition switch is turned on, the current flowing in Coil 1 sets up a magnetic field at its centre. The magnetic field attempts to draw the right-side soft-iron lobe in towards the centre of Coil 1 in the direction shown by the arrow, where the magnetic field is strongest. The current flowing in Coil 2 is always less than the current in Coil 1 by Mr Georg Ohm's Law, so the magnetic field produced by Coil 2 is always less than the field from Coil 1. Thus, although the smaller left-side lobe is attracted by the magnetic field from Coil 2, the Coil 1 field is always stronger.

Consider when the tank is full. As already noted, the sender unit's resistance will be approx. 10 ohms. As the sender resistance is connected in parallel with Coil 2 at 407 ohms, the current in Coil 2 is very small, with most circuit current passing through the Sender resistance. This means the magnetic field produced by Coil 2 is very weak, and the field produced by Coil 1 is much stronger.

With the Sender resistance at 10 ohms, the field from Coil 1 attempts to draw the larger right lobe towards the coil centre as shown by the arrow. At the same time, the much weaker field from Coil 2 has only a minimal effect on the smaller lobe, attempting to draw the small lobe towards the centre of Coil 2 as shown by the arrow. The result is the lobes are rotated anti-clockwise until the coil fields are in magnetic equilibrium with the two soft-iron lobes, which occurs when the soft-iron lobes have rotated to the point where the needle is pointing at the "Full" mark on the gauge.

Consider when the fuel in the tank has fallen from full to half full. The Sender resistance has increased to say 150 ohms, reducing the current flowing in Coil 1, but increasing the current flowing in Coil 2. (The total circuit resistance has increased so the current in Coil 1 has decreased.) Here, the magnetic field from Coil 1 is lowered, placing less magnetic attraction on the right-side lobe, while the magnetic field from Coil 2 is increased, placing more magnetic attraction on the left-side lobe. The net result is that the lobes rotate clockwise to the point of magnetic equilibrium, bringing the needle back to around the centre of the scale.

Consider when the fuel in the tank has fallen from half full to empty. When the fuel tank is empty, the Sender resistance has reached its maximum resistance of around 330 ohms. In this situation, the *current* in Coil 2 reaches its maximum level, causing the *magnetic field* from Coil 2 to reach its maximum level, drawing the small lobe closer towards Coil 2. At the same time, the total circuit resistance has reached its maximum, so the *current* flowing in Coil 1 is at a minimum, where the *magnetic attraction* from Coil 1 is also at its minimum and the *magnetic attraction* of Coil 2 is at its maximum. This results in the moving iron armature being rotated further clockwise to its point of magnetic equilibrium, which brings the needle to the "Empty" mark on the scale.

When the ignition switch is turned off, the magnetic fields from both coils are removed, and the large lobe drops and swings the needle to its left stop (its resting position).

From a design perspective, as shown in Photo 4, the two coils overlap each other to bring the centres of the two coils closer together to minimise the dimensions (and weight) of the moving iron armature and to minimise the total volume of the instrument for fitting inside the speedometer housing.

2CV Battery Meter:

The type of meter used for the battery meter is known as a thermal meter. It incorporates a small heating element (ala resistive heating wire) wrapped around a bi-metal strip. The heat (or power P in watts) from the heating element causes the bi-metal strip to deflect (bend) in response to the heat. The current I (amps) flowing through the resistive heating element R (in ohms) is directly proportional to the battery voltage E (in volts), i.e., $I = E / R$, but as the heat produced by the heating element is proportional to the square of the voltage, where $P = E^2 / R$, the battery meter could be calibrated in voltage, although the scale would be non-linear because of the squared voltage function. Citroen did not give the battery meter a voltage scale, but rather a colour-coded bar scale.

The circuit of the battery meter is shown at Fig. 4 below. The 12V terminal of the battery meter connects to the battery via the ignition switch and the Ground terminal connects to chassis ground. The heating element has a resistance of approx. 138 ohms in the writer's spare battery meter, so it draws around 100 mA of current from the battery when the ignition is switched on. The heating element is the only electrical component in the meter, as shown in Fig. 4.

Fig. 4. Internal circuit of battery meter

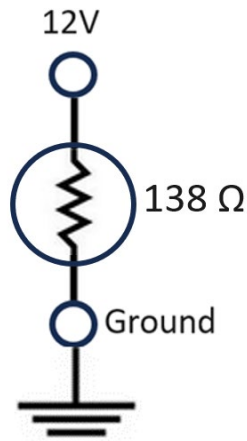

Photo 6. Front of Battery Meter

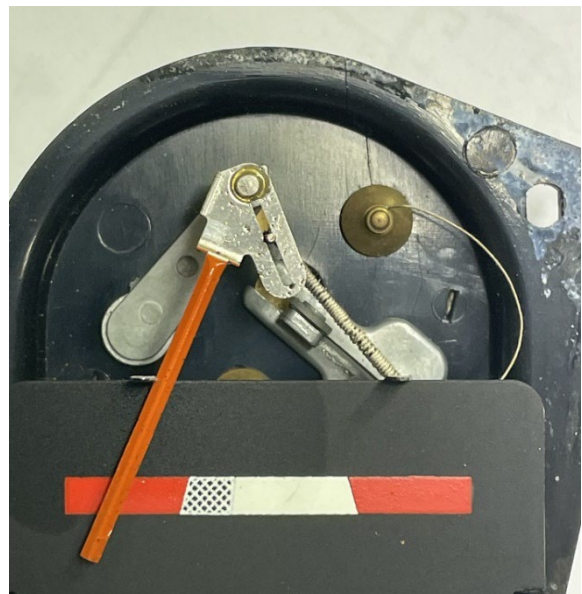

Photo 7. A little closer

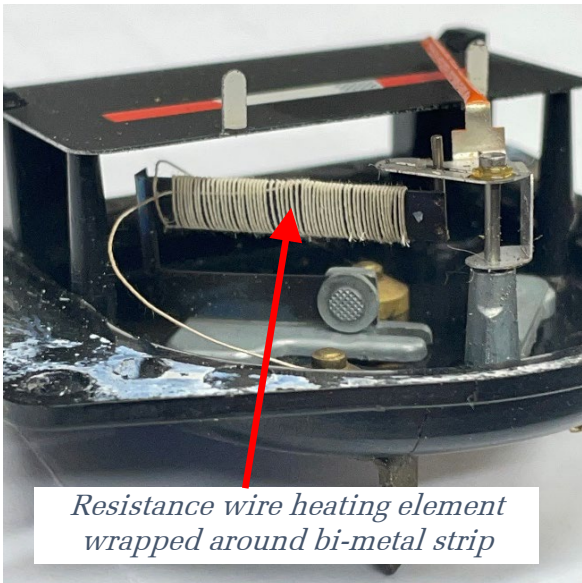

Photo 8. Inside views.

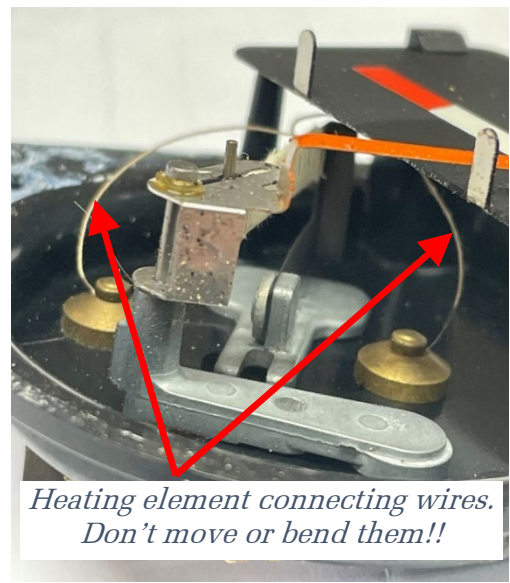

Photo 9

Unfortunately the photos don't provide sufficient clarity to allow the arrangement and action of the bimetal strip, which moves the needle, to be adequately observed and understood. This needs to be done by eye.

The thermal battery meter takes a short time (perhaps a minute) for the needle to reach its settling point due to the time it takes the heating element to warm up the bi-metal strip and for the bi-metal strip to deflect and move the needle to its target position. This type of meter is accordingly known as a heavily damped meter in control system theory. It would also be an ideal meter as a fuel gauge because of its slowness in response (to fuel motion in the fuel tank), but as its response is proportional to the square of the voltage ($P = E^2 / R$), it's unable to be used as a fuel gauge unless a separate voltage regulator is provided so as to maintain a constant voltage for its operation.

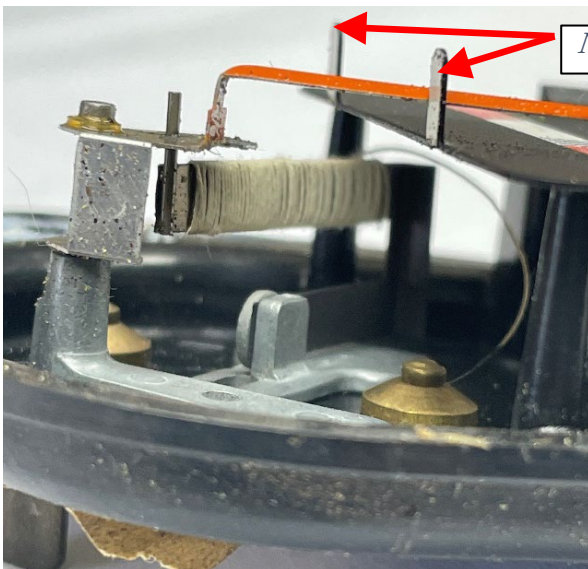

Photo 10

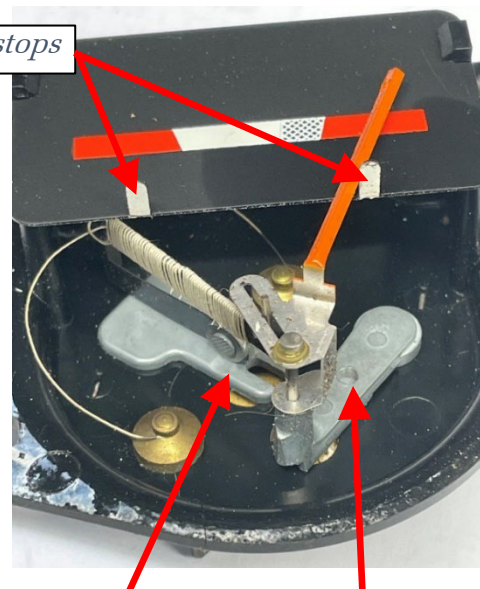

Photo 11. 12V adjuster and 15V adjuster.

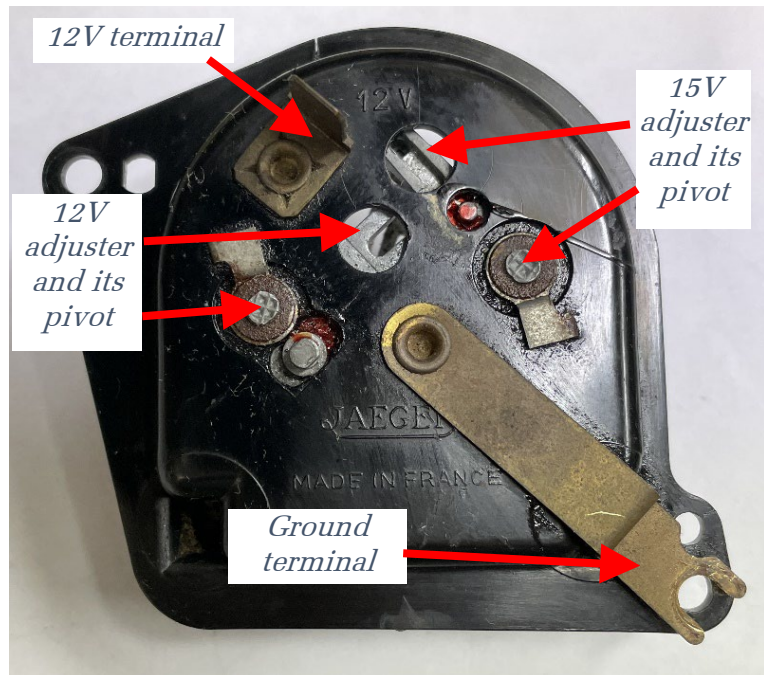

Photo 12. Rear of battery meter showing the two voltage calibration adjusters, the two adjuster pivots and the two electrical connections

Operation of Bi-metal Strip:

A bi-metal strip is formed by mechanically joining two metal strips of different thermal coefficients of expansion along their length. The two materials could be joined by being fused together, using rivets or being clamped together. This forms a structure which bends under temperature changes. Refer to Fig. 5 below.

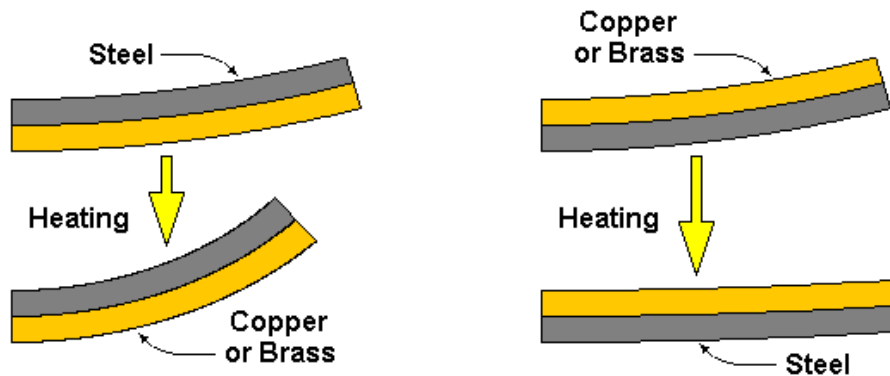

Fig. 5. Bi-Metal strip operation.

Steel typically has a thermal coefficient of expansion of 12 parts per million per degree Celsius (12 ppm/°C), whereas copper exhibits a larger coefficient of 16.6 ppm/°C and brass exhibits a still larger coefficient of 18.7 ppm/°C. When a steel strip is combined with either a copper or a brass strip, the combination responds to heating by *bending in the direction of the smaller coefficient of thermal expansion*, which in this case, is towards the steel. At the above-left figure, the slightly curved pair responds by bending towards the steel, increasing the structure’s curvature. At the above-right figure, the slightly curved pair responds by bending towards the steel, straightening the structure.

General Analysis of 12V Lead-Acid Battery Voltages:

A battery measuring 12.0 volts or less with the ignition off is partially discharged or is not being charged because of a voltage regulator/alternator fault. The battery meter needle should be in the lower red area.

A fully charged battery with ignition off will measure around 12.6 - 12.8 volts. With the Parking lights on, the voltage may be around 12.4 - 12.6 volts. The battery meter needle should be in the cross-hatched area.

A battery being charged will measure 12.5 - 14.5 volts. The lower figure could be with lights on and a partially discharged battery, where the needle is in the cross-hatched area. In this condition, the battery is being charged, then after perhaps an hour of driving, the needle should have moved up to the white area. The upper figure will be for a charged battery, where the figure is set by the voltage regulator's voltage set point. The needle will be in the white area. For the Bosch RE57 regulator, the voltage set point is 14.2V, in which case, the battery voltage should never exceed 14.2V while charging.

For 2CVs with the original mechanical voltage regulators, the battery charging voltage could be in the 14.5 - 14.6V range, which is at the top end of acceptability, while a charging voltage higher than 14.6V is definitely too high for the safe, long life operation of the battery, and the regulator should be adjusted to Citroen's specifications or else replaced with a modern solid-state voltage regulator like the Bosch RE57. No more regulator problems.

A battery voltage of 15.0 volts or more will cause the battery to boil its heart out from excessive charge current and it will become very hot to touch and is rapidly on a path to destruction (and possibly explosion!). This will be caused by a voltage regulator fault. The needle will be in the upper red area. STOP the engine immediately and allow the battery to cool down for a couple of hours. Alternatively, disconnect the rotor wire on the alternator to enable the driving to continue without the battery being charged, which is usually fine during daylight hours.

In normal running, with the battery fully charged, the needle should be in the white area.

Please note that these voltages may show some minor variations in different situations, including different ambient temperatures.

Calibration of the Battery Meter:

In view of the absence of any official Citroen calibration procedure for the battery meter, the writer has devised a calibration procedure based on the foregoing analysis of the typical lead-acid battery voltages and based on the coloured banding used for the battery meter scale.

To this end, the writer arbitrarily selected two voltage calibration points (set points) on the scale. The upper end of the lower red zone will be designated as the 12.0V set point, while the lower end of the upper red zone will be designated as the 15.0V set point. By arbitrarily choosing these voltage points at these scale positions, if the needle is in either red zone for any length of time, something is *definitely* wrong and needs to be corrected, as *these are the danger zones*. If the needle is in the cross-hatched area or the white area, the battery is in its normal working zone. (The writer suspects Citroen may also have considered the scale voltage points in this same manner, but we don't know...)

Photo 13 below shows the writer's selected positions for the two calibration points. The upper boundary of the left-most red zone will become the 12.0V set point and lower boundary of the right-most red zone will become the 15.0V set point. The scale also indicates the voltages at two intermediate points.

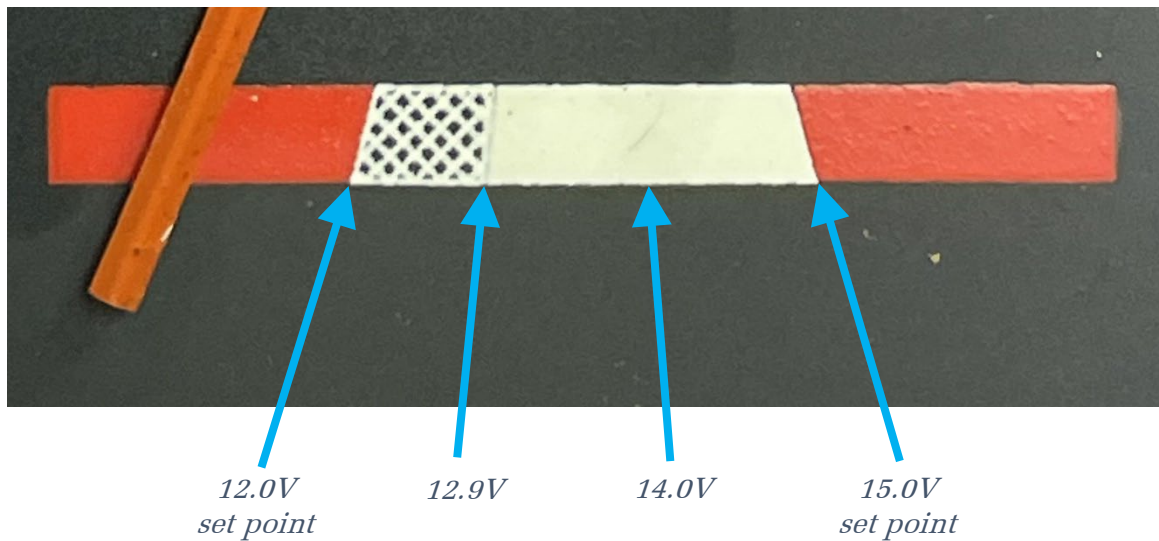

Photo 13. The writer's designated Battery Meter voltage set points

In summary, the lower red zone indicates the battery may not have sufficient charge to start the engine, while the upper red zone indicates a likely overheating of the battery, and none of us want our 2CV battery to exhibit either condition.

Battery Meter Voltage Adjusters:

The battery meter provides two adjustments for calibrating purposes: one is for adjusting the low voltage (12V) set point, and the other is for adjusting the high voltage (15V) set point. Once calibrated, the battery meter can provide an excellent indication of the battery status and the voltage regulator's performance.

Care of the Instrument:

Treat the battery meter (and the fuel gauge) with kid gloves. The moving parts are extremely delicate and light-weight and can be **very** easily damaged.

Don't place the instrument face down on the bench for fear of damage to the needle or the needle suspension. If the instrument has to be temporarily placed face down, return it to its position in the speedometer housing.

Battery Meter Removal Procedure:

After removing the speedometer from the vehicle, carefully place the dial glass face down on a clean cloth on the workbench. Remove the two screws securing the battery meter to the speedometer housing, then **very** carefully withdraw the battery meter directly outwards from the rear of the housing.

NOTE: Don't move/alter/bend the two wires connecting the meter's heating element to the external voltage connection terminals. These have been critically laid out so as not to interfere with or apply any stress to the free movement of the bi-metal strip and thus the meter's accuracy and linearity.

Ensure the calibration adjusters are free to move. From the rear of the meter (Photo 12), put a drop of penetrating fluid under the adjuster pivots, then *carefully* work each adjuster *sideways* with the tip of a screwdriver positioned in the slot of each adjuster. Ensure the adjusters move in a smooth manner. These haven't been moved for 30+ years so are likely to be firm/stiff, but they will move. Take your time.

Calibration Equipment Required:

The calibration of the battery meter requires the use of:

1. A variable DC voltage power supply with an output voltage in the range of 12 volts to 15 volts at a current of at least one amp.
2. A known-accurate 4-digit multimeter to measure DC voltages up to **15.00** volts.
3. Various connecting leads to suit.

The Procedure:

Keep the battery meter vertical when making the adjustments below and always allow time for the bi-metal strip temperature to stabilise after changing the power supply voltage or after making an adjustment. Also, any local air movement around the meter will affect the heating of the bi-metal strip, and thus the needle position, so minimise any movement of air near the meter.

1. Refer to Photo 12. With the power supply connected to the battery meter terminals (the polarity does not matter as it operates a heating element only), set the power supply voltage to exactly **12.00V** with the multimeter, then adjust the battery meter's 12V adjuster with a small screwdriver from the rear of the meter, moving the adjuster side to side until the needle is **exactly centred** on the upper edge of the lower red zone (at the 12.0V mark) in Photo 13. When satisfied all is correct and the needle position has stabilised, move to step 2.
2. Again, refer to Photo 12. Set the power supply voltage to exactly **15.00V** with the multimeter, then adjust the meter's 15V adjuster from the rear of the meter until the needle is **exactly centred** on the lower edge of the upper red zone (at the 15.0V mark) in Photo 13. Wait for the needle to stabilise.

There will be some interaction between these settings in that moving the 15V adjuster may alter the 12V setting and vice-versa, so repeat steps 1 and 2 until no further adjustment is needed. Take your time.

Note: The accuracy of the calibration of the battery meter is governed by the accuracy of the multimeter used in the procedure.

At this point, the battery meter has been calibrated to match the voltage points shown in Photo 13, and you now have a very useful voltmeter to monitor the battery status and the alternator/regulator operation.

Return the battery meter to the speedometer housing and secure it with its two screws. Once secured, place a small adhesive label over the two adjuster openings in the rear cover ala Photo 2 to stop dust and dirt from entering the meter movement in the future.

Conclusion:

The reader has been introduced to the theory of operation of the 2CV fuel gauge and battery meter and the manner in which they connect to the vehicle's electrical system. Basic diagnostic information has been provided for the fuel gauge and the battery meter. Also presented is the writer's procedure to calibrate the battery meter in a manner which provides useful information and maximises the status information shown by the coloured segments of the scale.

LIST OF ARTICLES BY THE WRITER

The articles written by the writer, listed below, may be freely downloaded from either of the following club websites by clicking on the adjacent links and locating the articles. Both websites maintain the latest revisions of the articles. Before using the articles, please ensure the latest revisions are being used, as the articles are updated on an as-required basis by the writer and given new revision numbers.

Citroen Classic Owners' Club of Australia: [Technical Articles](#)

Citroen Car Club of Victoria: [Tech Tips](#)

1. 2CV 40-Litre Fuel Tank
2. 2CV API GL-4 Gearbox Oil
3. 2CV Battery Charging Circuit
4. 2CV Battery Problems Solved
5. 2CV Brake Saga
6. 2CV Buyer's Questions
7. 2CV Carburettor Cover Screws
8. 2CV Carburettor Jets and Adjustments
9. 2CV Engine Problems
10. 2CV Fuel Filter
11. 2CV Fuel Gauge and Battery Meter
12. 2CV Gearbox Output Hubs
13. 2CV Gearbox Unwinding Debacle
14. 2CV Hard Luck Stories
15. 2CV Headlights Improvement
16. 2CV Ignition Coil
17. 2CV Knife Edges Replacement
18. 2CV Low Oil Pressure Beeper and Lights On Beeper
19. 2CV Maintenance - Part 1 of 2
20. 2CV Maintenance - Part 2 of 2
21. 2CV Oil Breather
22. 2CV Oils and Maintenance Advice From Burton
23. 2CV Points Ignition Reinstallation
24. 2CV Roof Rack
25. 2CV Secondary Choke Butterfly Adjustment
26. 2CV Spare Parts to Carry
27. 2CV Valve Clearance Adjustment
28. 2CV Workshop
29. Better Fuel Hose Clamps – **applies to all vehicles**
30. Better UHF CB Car Radio Performance – **applies to all vehicles**
31. Ignition Coil Ballast Resistors – **applies to all vehicles**

FINAL STATEMENT

My acknowledgement and grateful appreciation is given to the web sites from which photos/drawings/diagrams have been sourced.

If material copyrighted by others has been inadvertently used in this document without permission, then upon receiving advice, the writer will remove the material immediately.

This article may be updated in the future and assigned a new revision number.

Before using the information in this article, ensure the latest revision is being used.

If you have questions about the information in this article, if you find errors or incorrect statements, if you have suggestions for improvement, or should you wish to republish this article in your club magazine, please - contact the writer at: gdennes@gmail.com

The hosting or republishing of this article without the formal consent of the writer is not authorised and will constitute an infringement of copyright.

Copyright © Graeme Dennes 2023, 2024