

2CV 40-LITRE FUEL TANK

Revision 3



Graeme Dennes

2CV 40-LITRE FUEL TANK

Revision 3

Graeme Dennes

Background

The relatively small fuel tank in the 2CV can sometimes prove inconvenient for those who choose to travel in the wide open spaces. To ease this problem, the Burton Car Company in the Netherlands manufactures a 40-litre fuel tank kit intended as a drop-in (well, push up!) replacement for the 2CV's 25-litre tank. The tank kit includes the tank and all necessary mounting hardware. No permanent modification is made to the vehicle, which means the 40-litre tank may be removed at any stage and the original tank refitted. The 40-litre tank is shown at Fig. 1.



Fig. 1 40-litre fuel tank

The 40-litre tank uses the four original fuel tank mounting points as well as two additional mounting points provided by a metal bracket included in the kit. The bracket attaches to and runs between the two chassis rails to support the rear extension of the tank which holds the extra fuel, shown on the left side of the photo above. The extension fits between the chassis rails, per Fig. 2.

Burton also provides a YouTube video describing the fitting of the 40-litre tank in the 2CV, accessible at: [2CV 40-Litre Fuel Tank](#).

NOTE: *If the chassis of your 2CV is not original, it could be worth checking that the 40-litre tank will fit between the inner faces of the chassis rails, per Fig. 2.*



*Fig. 2 The 40-litre fuel tank, in the company of some left-over Red Centre dust!
Also shown is the tank's rear mounting bracket (supplied with the tank kit).*

Assembly Drawings

To assist with the installation of the 40-litre tank, the writer prepared drawings (below) showing the assembly of the mounting bolts and associated parts. Six bolts attach to the tank and two bolts attach to the chassis rails. The writer forwarded the drawings to Burton engineering staff, and Burton confirmed the drawings are correct.

When fitting the tank, use the drawings in conjunction with the procedure shown in the website video. Ensure the rubber fuel hose which attaches to the fuel tank's metal outlet spigot is in excellent condition regarding its integrity, reliability, security and safety, and is positioned so the rubber hose is not kinked or pinched, blocking the fuel flow. If in any doubt whatsoever about the integrity of the rubber fuel hose, replace it. It's much easier to do it now! Ensure the two electrical wiring connectors at the tank are clean and securely attached at the tank fittings and at the ground connection under the front-left tank mounting bolt.

Additional Tasks

If you decide to order the 40-litre fuel tank kit, you may choose to replace the fuel sender unit and its rubber gasket at the same time. These are not part of the tank kit, although the screws and fibre washers which secure the fuel sender in the tank are supplied with the tank kit. It may also be an opportunity to replace the stepped rubber joining sleeve which fits between the metal fuel filler pipe and the tank inlet fitting. Ensure the two metal circlips fitted to the joining sleeve are in good condition for the task.

2 x FRONT BOLTS

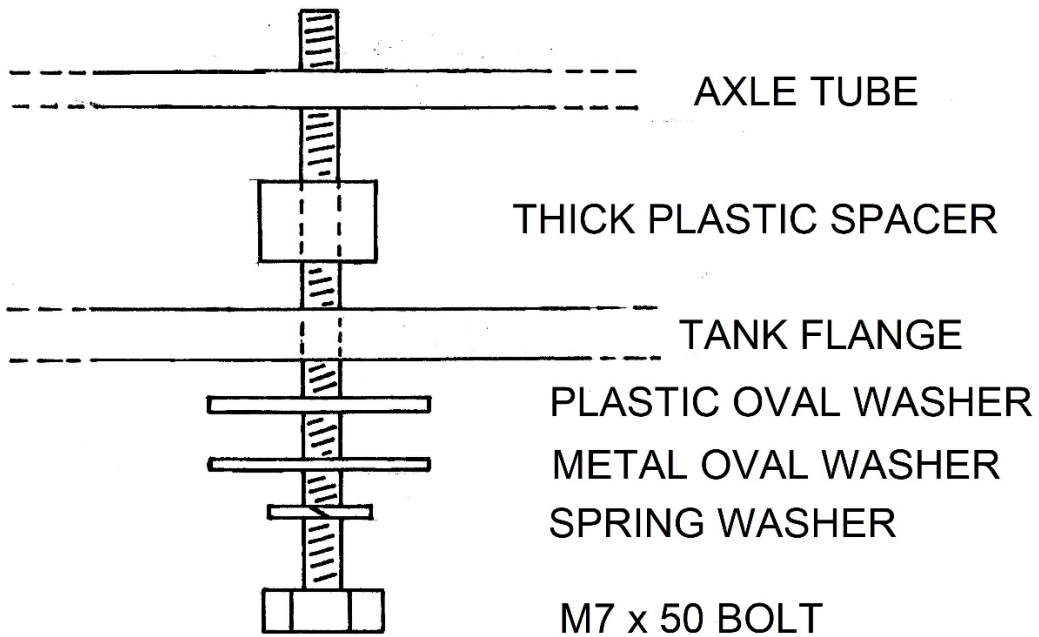

2 x SIDE BOLTS

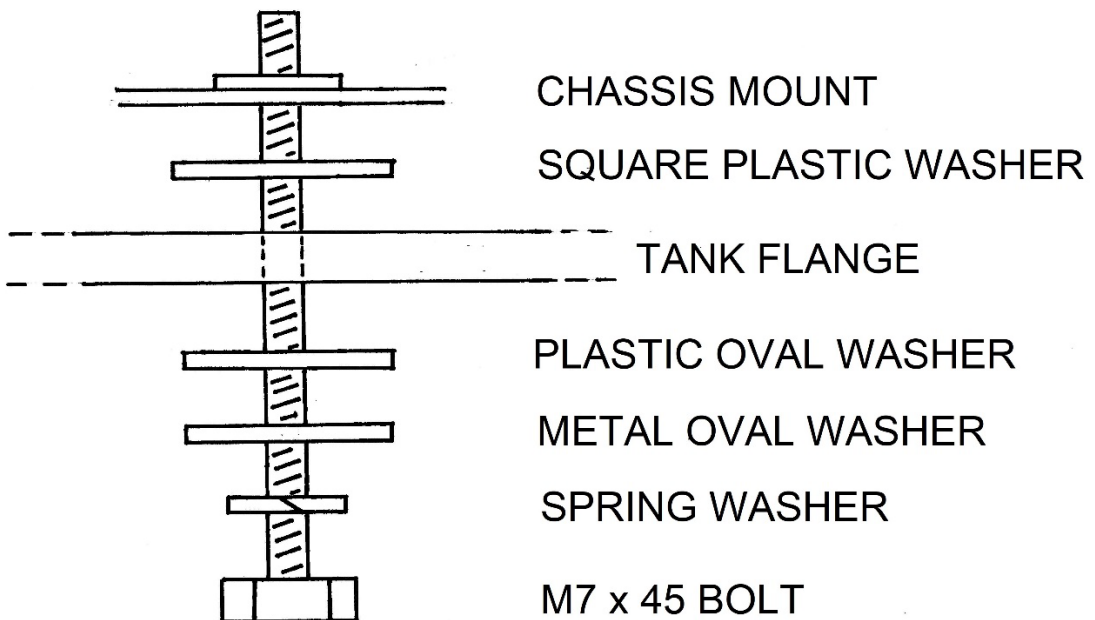

2 x REAR INNER BOLTS

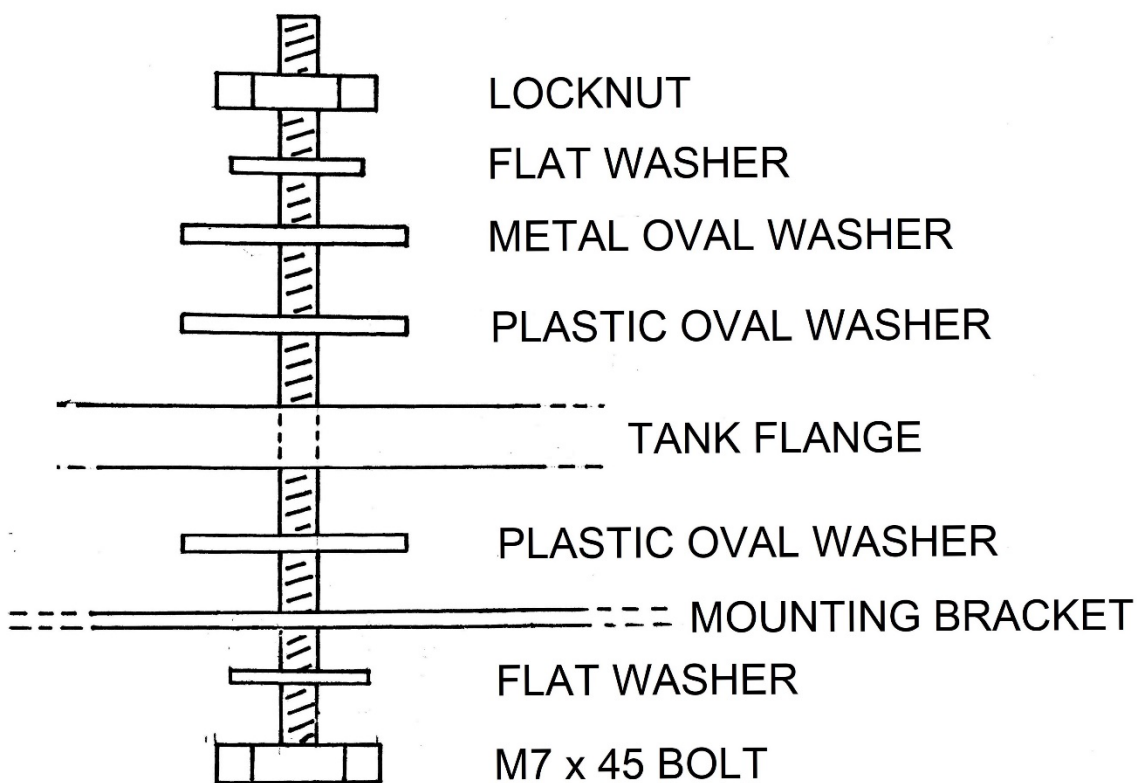

2 x REAR OUTER BOLTS

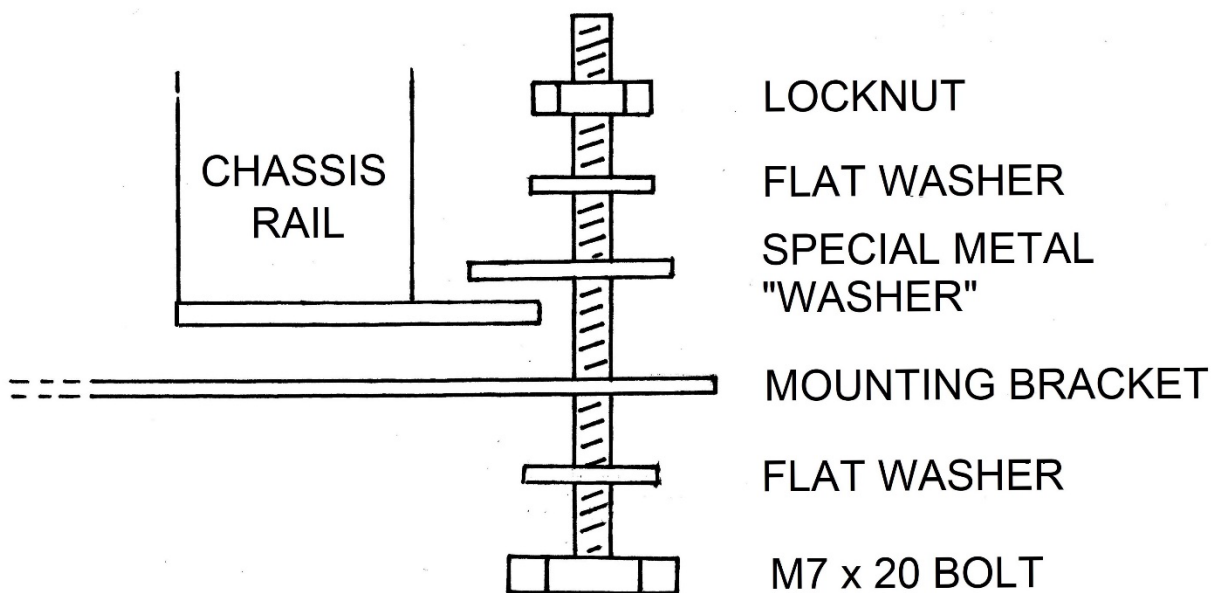

LIST OF ARTICLES BY THE WRITER

The articles written by the writer, listed below, may be freely downloaded from either of the following Citroen club websites by clicking on the adjacent links and locating the articles. Both websites maintain the latest revisions of the articles. Before using the articles, please ensure the latest revisions are being used, as the articles are updated on an as-required basis by the writer and given new revision numbers.

Citroen Classic Owners' Club of Australia: [Technical Articles](#)

Citroen Car Club of Victoria: [Tech Tips](#)

1. 2CV 40-Litre Fuel Tank
2. 2CV API GL-4 Gearbox Oil
3. 2CV Battery Charging Circuit
4. 2CV Battery Problems Solved
5. 2CV Brake Saga
6. 2CV Buyer's Questions
7. 2CV Carburettor Cover Screws
8. 2CV Carburettor Jets and Adjustments
9. 2CV Engine Problems
10. 2CV Fuel Filter
11. 2CV Fuel Gauge and Battery Meter
12. 2CV Gearbox Output Hubs
13. 2CV Gearbox Unwinding Debacle
14. 2CV Hard Luck Stories
15. 2CV Headlights Improvement
16. 2CV Ignition Coil
17. 2CV Knife Edges Replacement
18. 2CV Low Oil Pressure Beeper and Lights On Beeper
19. 2CV Maintenance - Part 1 of 2
20. 2CV Maintenance - Part 2 of 2
21. 2CV Oil Breather
22. 2CV Oils and Maintenance Advice From Burton
23. 2CV Points Ignition Reinstallation
24. 2CV Roof Rack
25. 2CV Secondary Choke Butterfly Adjustment
26. 2CV Spare Parts to Carry
27. 2CV Valve Clearance Adjustment
28. 2CV Workshop
29. Better Fuel Hose Clamps – **applies to all vehicles**
30. Better UHF CB Car Radio Performance – **applies to all vehicles**
31. Ignition Coil Ballast Resistors – **applies to all vehicles**

FINAL STATEMENT

My acknowledgement and grateful appreciation is given to the web sites from which photos/drawings/diagrams have been sourced.

If material copyrighted by others has been inadvertently used in this document without permission, then upon receiving advice, the writer will remove the material immediately.

This article may be updated in the future and assigned a new revision number.

Before using the information in this article, ensure the latest revision is being used.

If you have questions about the information in this article, if you find errors or incorrect statements, if you have suggestions for improvement, or should you wish to republish this article in your club magazine, please - contact the writer at: gdennes@gmail.com

The hosting or republishing of this article without the formal consent of the writer is not authorised and will constitute an infringement of copyright.

Copyright © Graeme Dennes 2021, 2025