

# IGNITION COIL BALLAST RESISTORS

Revision 9



Graeme Dennes

# IGNITION COIL BALLAST RESISTORS

Revision 9

Graeme Dennes

Please note: The Citroen 2CV does not use an ignition coil ballast resistor.

## **Background**

In the years leading up to 1970, the vast majority of motor vehicle ignition coils were “12V” coils, designed to operate from a 12V supply, i.e. from the standard 12V vehicle battery.

### ***But there is a weakness, m’lord***

*What are you on about Baldrick?* Well, m’lord, although the “12V” coil was manufactured and used for many years, it does possess a fundamental weakness. When starting a petrol-ignition engine, maximum spark energy is needed to ensure the fuel mixture in the cylinders is properly ignited at the relatively slow cranking speed of the engine. However, while the starter motor is turning the engine over, the high current drawn by the starter motor (several hundred amps) results in the battery terminal voltage falling somewhat because of the voltage dropped across the battery’s internal resistance. (Dr Georg Ohm has something to do with that!)

The drop in terminal voltage will be exacerbated if the battery is in an undercharged, weakened or aged state or if the ambient temperature is low. Such conditions never fail to conspire to reduce the battery’s ability to deliver the required starter motor current. Under these conditions, m’lord, the battery terminal voltage may drop to as low as 9V, resulting in slower starter motor operation and slower engine cranking speed. Of itself, this is generally not a major issue and should not prevent the engine from starting. It just may take an extra second or two. (It could also be an indicator that all is not well with the health of the battery or its charging system.) *So then, what’s all the fuss about Baldrick?* The problem, m’lord, is that when operating with a reduced battery voltage of say 9V, the “12V” ignition coil *will produce a weak spark* which may well prevent the engine from starting. Not because of a slower cranking speed but because of a weakened spark!

In summary, at the very moment we need the *strongest* spark (starting the engine), the “12V” coil may be operating from a 9V supply instead of 12V for which it was designed, guaranteeing it will produce a weak spark and possible starting problems. *I think I see a cunning plan, m’lord.*

### ***A Cunning Plan? What are you talking about Baldrick?***

The cunning plan, er, solution, offered by most vehicle manufacturers was to fit a resistor, known as a ballast resistor, in series with the coil primary winding. The ballast resistor is a low-ohms resistor, designed to reduce the voltage being supplied to the coil. *Its resistance is specified by the vehicle manufacturer* so that while the engine is operating, the ballast resistor has typically 3V dropped across it, with the remaining 9V acting as the supply voltage to the coil. *Whaaaat? What exactly have you been taking Baldrick?*

With this arrangement, m’lord, the idea is that the coil *is designed from the start* as a “9V” coil which uses a ballast resistor, i.e. specifically designed to provide the necessary spark energy *when operating from a 9V supply!* Thus, the running performance of the “9V” coil when operating from a 9V supply (i.e., with the ballast resistor) is *identical* to the performance of a “12V” coil operating from a 12V supply (i.e., without a resistor).

No differences in their spark production or engine performance will be observed when the coils are operating at their respective design voltages, so neither the engine nor the driver will know whether a “9V” coil and ballast resistor is fitted, or a “12V” coil and no resistor is fitted – *so long as the battery is fully charged* (he says knowingly...). Ok, so where to from here?

***Look Baldrick, why go to all this trouble?***

Well, m’lord, when the ignition switch is turned to the Start position, the starter solenoid is activated and the starter motor operates as usual. At that same time, and here’s the cunning plan, the ballast resistor is bypassed, meaning the 12V feed from the ignition switch is connected *directly* to the coil’s “+” terminal, so the “9V” coil is temporarily connected to the 12V battery supply instead of its usual 9V supply via the ballast resistor.

*And the purpose is, Baldrick?* The purpose, m’lord, is to ensure a solid spark is produced during engine startup to help compensate for a possibly weakened, lower-voltage battery. Even if the battery voltage falls to as low as 9V during starting, the “9V” coil is (still) operating from a 9V supply (the ballast resistor being bypassed), exactly as it was designed to do, and the spark is fat! Once the engine starts and the ignition switch is released, the temporary 12V direct feed to the “9V” coil is disconnected, and the ballast resistor is again put back into the circuit, supplying 9V to the “9V” coil and the world is good. Yes, a strong spark and a happy owner.

Historically, it seems ballast resistors were introduced into vehicle ignition systems around the time the electrical systems were making the transition from 6V systems to 12V systems, i.e., when car batteries changed from 3-cell 6V lead-acid batteries to 6-cell 12V lead-acid batteries. The transition from 6V to 12V systems was certainly underway in the 1950s and continued into the 1960s.

**Different Types of Ignition Systems**

The three circuit diagrams which follow are representative-only of the principles employed when using ballast resistors and “9V” coils with the three common ignition system types being used at the end of the 1970s: the points ignition system, the transistor-assisted ignition system and the transistor ignition system.

A point to note with all three diagrams is that the ignition switch pole has three positions: the OFF position, the ON position and the START position. In the START position, the 12V battery voltage is fed from the ignition switch pole to the *two* Start contacts, which are bridged by the ignition switch pole. One contact connects to the “+” terminal of the ignition coil primary winding to bypass the ballast resistor, while the other contact connects to the starter motor solenoid to activate the starter motor. Both connections are necessary to start the engine. Numerous wiring arrangements, some novel and some overly complex, were used by vehicle manufacturers to make these connections. No single method was used. Check the workshop manual for your vehicle to identify the wiring arrangements used.

## Type 1: Points Ignition System

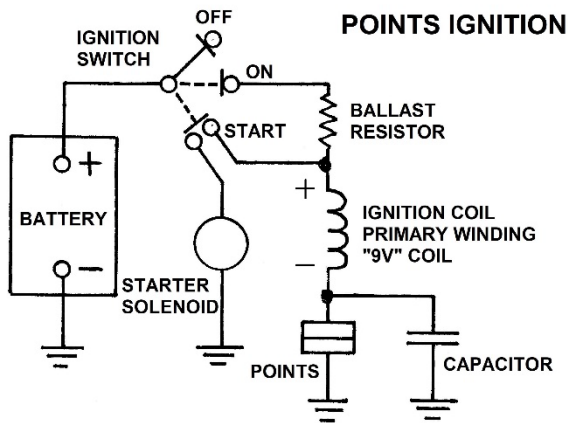

Standard points ignition system with ballast resistor, "9V" coil, points and capacitor.

The diagram on the left shows the basic wiring arrangements when using the ballast resistor and "9V" coil in the standard *points ignition system*. In the Start position, the 12V battery connects directly to the "9V" coil, bypassing the ballast resistor. The battery also connects to the starter solenoid. After the engine starts and the ignition switch is released to the ON position, the ballast resistor is reconnected back in series with the coil primary winding, and the ignition coil "+" terminal and the starter solenoid are disconnected from the battery. In summary, m'lord, that's the reason a "9V" coil and ballast resistor are used - to ensure a solid spark is produced during engine starting, even if the battery voltage falls to as low as 9V.

*Well, Baldrick, I have to agree. A very simple and cunning plan! Yes, m'lord, it is a cunning plan! In fact, m'lord, it's the most cunning plan a Baldrick has had for five hundred years!*

### ***So, Baldrick, how do we select the ballast resistor?***

Well, m'lord, the vehicle manufacturer specifies the coil and ballast resistor to be used, so when a vehicle is manufactured with a particular coil and ballast resistor, the coil and resistor become an *intrinsic, inseparable pair for the life of the vehicle and are listed in the specifications of the vehicle's ignition system*. The ballast resistor is not optional nor at the whim of the owner. *So, Baldrick, back to the question. How do we select the ballast resistor? We don't, m'lord. The vehicle manufacturer does!*

### ***Then how am I supposed to know if a ballast resistor has been fitted?***

It's very simple, m'lord. We determine this by voltage measurement with the ignition on, the engine off and the points closed, as follows:

Step 1: Turn on the ignition switch with the engine off.

Step 2: To ensure the points are closed, measure the voltage at the *negative* terminal of the coil. If it reads around 3V or less, *the points are closed*, as we require, so move on to step 3. If it reads around 9V or more, *the points are open*, in which case the crankshaft needs to be turned a little more and Step 2 repeated.

Step 3: To check if a ballast resistor is fitted, measure the voltage at the *positive* terminal of the coil. If it reads around 9V, a ballast resistor is fitted. If it reads around 12V, it is not fitted.

## Type 2: Transistor-Assisted Ignition System

The first foray of electronics into vehicle ignition systems was focused on relieving the points of the high current drawn by the coil primary winding, typically several amps. The purpose of the change was to improve the reliability of the ignition system and lower the vehicle's maintenance requirements by reducing the current passing through the points, which in turn reduces the wear on the points and thus the points maintenance. Under this new arrangement, the points act as a low-current switch, operating a power transistor which carries the coil primary current.

This type of ignition system is known as *transistor-assisted ignition*, where the points are assisted by the transistor taking over the role of supplying the (high) current to the coil. This considerably lightens the electrical load on the points, extending the points service interval and service life. The transistor is analogous to a relay, operated by the switching action of the points. When the points are closed, the transistor is turned on and supplies the current to the coil primary winding. When the points open, the transistor is turned off, turning off the current through the coil which in turn produces the high voltage for the spark plugs.

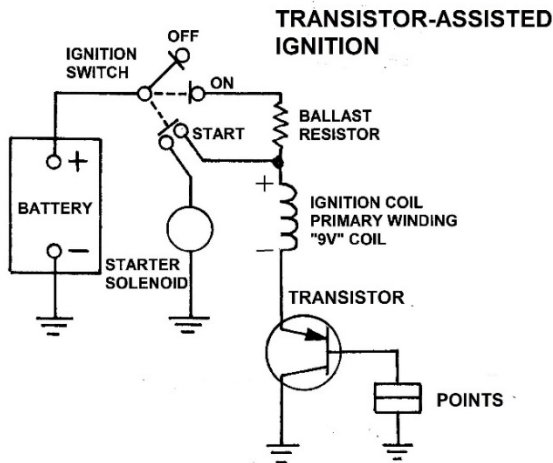

Transistor-assisted ignition system with ballast resistor, “9V” coil, transistor and points.

The diagram on the left shows the basic wiring arrangements for using the ballast resistor and “9V” coil in the *transistor-assisted ignition system*, where the points are assisted by a power transistor carrying the coil current, relieving the points of the coil current. The transistor and its associated circuitry are located in a small electronics module in the engine bay. Transistor-assisted ignition systems started to appear in production vehicles around 1963.

### Points “Wetting” Current:

Theoretically, the points could operate with say one microamp of current passing through them, ensuring they would last a hundred years, but such a low current is insufficient to ensure the points contact faces remain clean. A higher points current is needed to “burn off” any surface oxidation. Unlike a typical switch where the metal faces of the contacts are kept clean by the wiping motion of the sliding contact faces each time the switch is operated, no such self-cleaning action occurs with points. The insulator block, driven by the cam on the distributor shaft, provides a simple push-open / self-close action only. No sliding motion so no self-cleaning. If the points current is too low, it will only be a short time before surface oxidation on the faces of the points causes them to remain open-circuited, preventing the engine from starting or running.

The solution commonly used to keep the points faces clean is to pass a “wetting” current of typically 25 to 50 milliamps through the points when the points are closed. This is the *minimum* current necessary to provide a self-cleaning action by breaking down any surface oxidation film on the faces of the points, keeping them clean and keeping the contact resistance low.

In summary, the **first** inroad of electronics into vehicle ignition systems focused on relieving the points of the coil primary current by handing it over to a power transistor. The key benefit achieved was extended service intervals and extended points life.

### Type 3: Transistor Ignition System

The next entry of electronics into vehicle ignition systems, and which is a refinement of the transistor-assisted ignition system described above, was aimed at doing away with the points altogether and replacing them with an *adjustment-free* electronic sensor.

This type of ignition system is known as *transistor ignition*. The sensor was in several forms. One of the earliest was an optical sensor which had a light beam directed onto it. The sensor is located on the distributor breaker plate and is activated by a set of rotating vanes interrupting the light beam, the vanes being driven by the distributor shaft. As each vane interrupts the light beam, it triggers the optical sensor, which turns off the power transistor carrying the coil primary current, generating a spark from the coil.

The optical sensor was not very successful in the under-bonnet environment due to moisture, dirt, grime, oil etc entering the distributor housing and settling on the light source and sensor, interfering with their operation and eventually preventing the engine from starting. Can I clean your windscreen and ignition sensor sir? Yes, thank you.

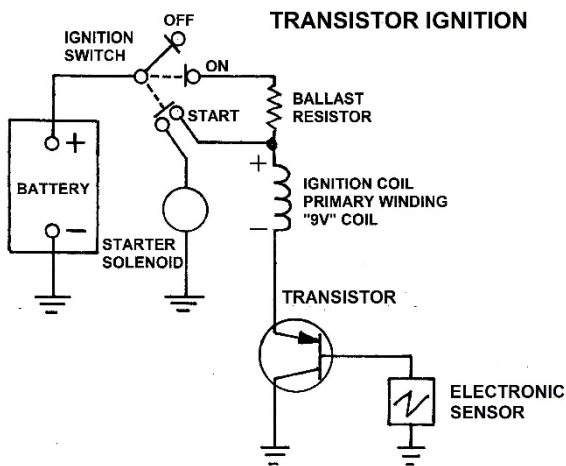

The diagram on the left shows the basic wiring arrangements for using the ballast resistor and “9V” coil in the *transistor ignition system*, where the power transistor carries the coil current as before but the transistor is controlled by an electronic sensor instead of points. What? No points? Yes, adjustment-free! Ah, that’s better! Most production vehicles were fitted with transistor ignition systems by around 1975.

Transistor ignition system with ballast resistor, “9V” coil, transistor and electronic sensor.

### More Reliable Sensors

Due to the weaknesses inherent in optical sensors when used in the unfriendly environment under the bonnet, more reliable sensors were needed. One of the earliest was the inductive pickup coil. This consisted of several hundred turns of fine wire wound into a coil on an iron core, and via electromagnetic induction, a small voltage is induced in the winding when a strong magnetic field passes across the winding. The usual arrangement was to use an assembly of several pickup coils mounted radially on the breaker plate inside the distributor, with one pickup used for each cylinder. A magnet is rotated by the distributor shaft, and as the magnet passes each inductive pickup in turn, the voltage induced in the pickup is used to turn off the power transistor, which turns off the current in the ignition coil and the coil produces a spark at a plug.

Another reliable electronic sensor is the Hall-Effect sensor. This responds to the presence of a magnetic field and is used in place of the inductive pickup coils noted above.

In summary, the **second** entry of electronics into vehicle ignition systems was to replace the points with an electronic sensor, finally achieving an adjustment-free solution to spark generation. Once the timing was set, no further ignition adjustments were required, theoretically, for the life of the vehicle.

By the end of the 1970s:

1. Most new vehicles incorporated a ballasted (“9V”) coil and ballast resistor to reduce engine starting problems.
2. Most new vehicles incorporated a *transistor ignition system* to increase reliability and provide adjustment-free ignition.

## Modern Electronic Ignition Systems

Today's electronic ignition systems are a far cry from the original transistor ignition systems discussed above. They are still based on the diagram above, but the development of dedicated ignition switching transistors has been rapid over the last two decades. The most recent transistors (IGBTs) have essentially reached a state of perfection for the task at hand, being able to operate under very high voltage and current conditions with very short switching (on-off) times. They are also much more reliable than their 1970s predecessors. Further, modern ignition systems use fully electronic circuitry to vary the ignition timing in response to engine speed and engine load, increasing the ignition advance as engine RPM increases and decreasing it as engine loading increases.

## Summary

In summary, whether your vehicle uses a points ignition system, a transistor-assisted ignition system (using points) or a transistor ignition system (using an electronic sensor), the ballasted ("9V") coil and ballast resistor are wired and operate in an *identical* manner in these ignition systems. The ballasted coil will not know whether the coil primary current is being interrupted by points or a power transistor! At the block diagram level, there is no difference in the functional operation of these ignition systems (excluding the points and sensors of course), and they produce the same responses to electrical diagnostic tests. Even so, your vehicle's workshop manual should always be consulted when conducting ignition system diagnostic tests to ensure a proper understanding is gathered of the particular arrangements implemented by the manufacturer and the test methods required for diagnostic purposes.

## Some Rules

There are some important rules which apply too, m'lord. *Rules? What rules, Baldrick?* A ballasted ("9V") coil is designed to be used with a ballast resistor. Should the owner decide, for whatever reason, to remove or bypass the ballast resistor but retain the ballasted coil, the "9V" coil will see a permanent connection to a 12V supply, increasing the current in its primary winding to the same level as when starting the engine. However, instead of the increased current being present for only a few seconds during the engine start, the increased current has become an ongoing "feature" of the vehicle!

Yessiree Bob, this is guaranteed to do *at least* one thing – overheat the coil. It's the result of operating a "9V" coil continuously from a 12V supply, something for which it was never designed. The heat dissipated in the coil is almost doubled, being that the heat is proportional to voltage squared, i.e.,  $12^2 / 9^2 = 1.8$  times. *Not surprisingly, the coil may well overheat and be destroyed!* Yes indeed, an expensive decision!

**Rule 1:** Never run a ballasted coil *without its specified ballast resistor*.

**Rule 2:** If a ballast resistor becomes faulty, replace it with the identical (or equivalent) type and *definitely of the same resistance*.

**Rule 3:** There is no such thing as a "standard" ballast resistor. A ballasted coil requires the exact ballast resistor specified for it by the vehicle manufacturer. This is not about opinion! The resistance of the ballast is established during the design of the coil. As already noted, the coil and resistor are specified as a pair of items with specific part numbers to be used together for the life of the vehicle. *Do not mix and match!*

**Rule 4:** A question: Should I fit a ballast resistor to my car? The answer: If the coil is designed by the manufacturer to operate *with* a ballast resistor ( a “9V” coil), the *specified* ballast resistor should be fitted. If the coil is designed to operate *without* a ballast resistor (a “12V” coil), do not fit one. Nothing more. Nothing less.

**Rule 5:** I have seen a situation where a vehicle owner replaced a faulty ballasted (“9V”) coil with a non-ballasted (“12V”) coil to resolve a problem. In such situations, the ballast resistor will need to be removed or bypassed because the “12V” coil is designed to operate *without* a ballast resistor. Leaving the ballast resistor in circuit with a “12V” coil will guarantee a reduction in spark intensity from the coil and may prevent the engine from starting or running.

The irony of this change is that replacing the “9V” coil and resistor with a “12V” coil will remove the very benefits bestowed by the ballasted solution – *the ability to produce a solid spark at low battery voltages during engine starting*, the *raison d’etre* for using the ballasted coil and ballast resistor! If the removal of the ballasted coil and ballast resistor solves a problem, then either the original coil, the original resistor or the wiring has a problem.

### **Removal of Ballast Resistor**

If a vehicle is manufactured with a ballasted coil and ballast resistor and the owner decides to remove or bypass the ballast resistor, they do so at their peril. Refer to Rule 1. The *removal* of the ballast resistor is *not the solution to fixing a hard to start engine or achieving a stronger spark*. If an engine is hard to start, something (else) is causing it. Of course, ballasted coils and ballast resistors can fail, just as any other vehicle component can, in which case, simply replace same with same!

### **Some Options**

**Option 1:** If your vehicle was manufactured with a ballasted (“9V”) coil and ballast resistor and you need to replace the coil or resistor, it is always preferable to purchase *new* genuine items from the vehicle manufacturer, as those items are designed specifically for your vehicle, backed by the manufacturer’s guarantee of quality, performance and reliability.

**Option 2:** If the items are no longer available from the manufacturer, as eventually happens with older vehicles, the next-best option is to purchase the item from a recycled car parts supplier for your *specific* vehicle model. At least you will have *genuine* factory-made items, made for your vehicle, removing any performance, mounting or wiring issues.

**Option 3:** If that option is not available, there may be global suppliers of new, after-market items specified for your vehicle. This way, the after-market manufacturer has taken on the R&D responsibility to ensure the items will *successfully fit, mount, connect to and operate* in your vehicle, as well as providing a warranty. A no-risk solution.

**Option 4:** Advice may be available from local or international car clubs whose members may have already done the hard yards, er, metres, and identified a suitable alternative solution for your vehicle.

**Option 5:** If the previous options are not available, then as the least-recommended option, you would need to develop your own R&D solution for a ballasted coil and ballast resistor. There may be some R&D risks in achieving a satisfactory outcome here because you could be working somewhat “in the dark” if you have no prior information! Further, because you will be experimenting with the ignition system in your vehicle, and because the ignition system is intrinsically critical to the engine’s operation, performance, reliability and life, you may be less inclined to pursue this DIY path! Still, it is an option.

**Option 6:** Finally, if all else fails, a last resort option is to remove the ballasted coil and ballast resistor and fit a suitable non-ballasted (“12V”) coil wired in standard fashion. The disadvantage of this option is that it removes the starting benefits provided by the ballasted solution.

### **Fitting a ballasted coil and ballast resistor for the first time**

This option makes perfect sense, as it confers the benefits of the ballasted coil. If intending to fit a ballasted (“9V”) coil and ballast resistor to a vehicle which didn’t have them fitted by the manufacturer, there may be suppliers of new after-market parts for your vehicle. Again, car clubs may also be able to assist with advice. If that option is not available, then you would need to develop your own ballasted coil/ballast resistor solution for your vehicle.

### **Ignition System Example**

To assist the reader’s understanding, we will do a cross-check on the ignition system specifications for the 1978 Ford Fairlane 500 model ZH. This vehicle uses a ballasted coil and ballast resistor with a transistor ignition system and electronic sensor. Similar ignition systems were being used by most vehicle manufacturers by that time.

On a historical note, the 1978 Fairlane engine uses the two traditional ignition timing advance mechanisms: mechanical timing advance which is proportional to engine RPM, and vacuum timing advance which is inversely proportional to engine load. These were being used by almost every petrol vehicle manufactured at that time. It took until 1980 for electronic control of ignition timing to start to appear in new vehicles, doing away with the mechanical and vacuum advance mechanisms for purposes of improving the reliability and simplifying the maintenance.

Consider some of the key ignition system specifications drawn from the Fairlane workshop manual:

Nominal battery voltage (engine off)	= 13.0V
Ballast resistor	= 0.9 ohms
Ignition coil primary resistance	= 1.7 ohms
Transistor on-resistance	= (nominally) zero ohms
Coil current (ignition on, engine off)	= 5 amps

As an exercise, we will calculate the design voltage of the coil:

1. Firstly, confirm the figure of 5 amps for the coil primary current:  
The total coil primary circuit resistance is the sum of the ballast resistor (0.9 ohms), the coil primary winding resistance (1.7 ohms) and the transistor on-resistance (nominally zero ohms)

$$\begin{aligned} &= 0.9 + 1.7 + 0 \\ &= \mathbf{2.6 \text{ ohms}} \end{aligned}$$

With 13V from the battery:

$$\begin{aligned} \text{Coil primary current} &= 13\text{V} / 2.6 \text{ ohms} \\ &= \mathbf{5 \text{ amps}}, \text{ as specified in the manual} \end{aligned}$$

2. Next, calculate the voltage dropped across the ballast resistor:  
Ballast resistor voltage = ballast resistance (ohms) x coil primary current (amps)  
$$\begin{aligned} &= 0.9 \text{ ohms} \times 5 \text{ amps} \\ &= \mathbf{4.5\text{V}}. \end{aligned}$$

3. Next, calculate the coil supply voltage:

$$\begin{aligned}\text{Coil supply voltage} &= \text{battery voltage} - \text{ballast resistor voltage} \\ &= 13\text{V} - 4.5\text{V} \\ &= \mathbf{8.5\text{V}}\end{aligned}$$

In summary, this indicates the supply voltage to the coil (via the ballast resistor) is **8.5V**, i.e., the coil is an “**8.5V**” coil, designed to operate from an **8.5V** supply. All done.

### Types of Ballast Resistor

Commonly, ballast resistors are manufactured in two forms - a discrete electrical component (module) which will be mounted closely to the ignition coil. These can be of various sizes, shapes, mounting arrangements and wiring terminations.

Ballast resistors can also be in the form of an electrical cable. These are made from resistance wire, similar to the wire used in the heating element of a toaster. This cable will usually be connected to the coil positive terminal at one end and the ignition switch ON connection at the other end. Be careful when handling the cable and when disconnecting or reconnecting its terminals. Given that it is made of resistance wire, it may exhibit a degree of stiffness, meaning it won't take as much handling or bending as normal multistrand (flexible) copper cable. Don't bend or reshape it unless absolutely necessary.

### Nominal Figures

The example ballasted coil discussed in this article is a “9V” coil, designed to operate from a 9V supply. This figure is used as a representative figure only. Ballasted coils in some vehicles are designed to operate at even lower voltages such as 7V. Check the vehicle's ignition system specifications for the figures that apply to the vehicle. There were no standards. Every manufacturer made their own decisions here.

### Before Ballasted Coils

Vehicles built *before* the introduction of ballasted coils and ballast resistors are much more dependent upon the battery and charging system being maintained in a sound state of health and the battery maintained in a charged condition. Any shortfalls here will result in lower voltage from the battery, and so the starter motor will turn slower and the ignition coil will produce a *weaker* spark which may prevent the engine from starting.

### Misinformation

*Misinformation? Whatever are you talking about Baldrick?* Well, m'lord, unfortunately, there is no shortage of misinformation and misunderstanding being perpetrated on the internet about ballasted coils and ballast resistors (or any other subject!) which can result in a great deal of confusion and risk, and potentially damage. The vast majority of the information presented is anecdotal, i.e. information based on *unsubstantiated personal experience or personal opinion*. Some of the information is situation-specific and undefined, some is only a part of a greater picture, some is quite dubious and some is plainly wrong, yet *many people blindly accept it as being the truth without question, simply because it is being offered!*

Like almost everything else on the internet, there are far more personal *opinions* expressed about an issue than there are true hard *facts!* Most such opinions never get around to involving or discussing the hard facts – the *true* underlying facts underpinning some idea, item, arrangement or operation, but that never stops someone from giving you *their opinion or view, sans the hard details!* Unfortunately, and despite their best intentions, some writers don't know what they don't know, and anyone who reads their advice won't know that the writers don't know what they don't know!

The writers may feel chuffed about making a contribution, but unknown to the writer, their advice may be situation-dependent, incomplete, inconclusive or wrong, and *wrong* advice is anything but helpful and may even be harmful or destructive! A writer's *interest* in a subject does not, in and of itself, imply knowledge and understanding of the subject. *How will you decide if the advice provided in your internet searches is correct?* If you do web searches for information, be careful before accepting and acting on anecdotal information on *any* subject. Consider the source. Corroborate the information from at least several sources to ensure it's not simply someone's *opinion!* Do your due diligence. You may be very thankful you did!

### **Some History**

During the 1960s and 1970s, significant developments and experiments were being undertaken by the major automotive manufacturers and electronic component manufacturers to establish the forerunners of the ignition systems we use today. As options for new car buyers, the early transistor ignition systems were expensive and were not universally included in all new cars purchased.

The reader is referred to an informative 3-part article in *Curbside Classic* titled *Automotive History: Electronic Ignition - Losing the Points*. It discusses the history of automotive electronic ignition systems and is well worth reading as it contains historical technical details about vehicle ignition systems, the forerunners of today's ignition systems. Although the 3-part article focuses primarily on the then USA's Big Three (GM, Ford and Chrysler), all global vehicle manufacturers were running similar development programs in parallel, facing similar issues and needs. No manufacturer was an island during those early development years of automotive electronics.

The three parts of the article are accessible via the following links. My thanks to Curbside Classic for making the articles freely available.

Part 1:

<https://www.curbsideclassic.com/automotive-histories/automotive-history-the-history-of-electronic-ignition-losing-the-points-part-1/>

Part 2:

<https://www.curbsideclassic.com/automotive-histories/automotive-history-electronic-ignition-losing-the-points-part-2/>

Part 3:

<https://www.curbsideclassic.com/automotive-histories/automotive-history-electronic-ignition-losing-the-points-part-3/>

### **Conclusion**

The ballasted coil and ballast resistor combination is a simple, low-cost and effective solution to the problem of a weakened spark during engine starting caused by a lowered battery voltage. The ballasted coil and ballast resistor provided excellent service to the automotive industry over several decades before being superseded by modern electronic ignition systems.

A note: Ignition systems in today's new vehicles are a far cry from the ignition systems discussed above, and although basic ignition system functionality hasn't changed (engines still require a spark at the correct moment), the modern implementations bear little resemblance to the ignition systems used in vehicles built in the twentieth century.

## LIST OF ARTICLES BY THE WRITER

The articles written by the writer, listed below, may be freely downloaded from either of the following club websites by clicking on the adjacent links and locating the articles. Both websites maintain the latest revisions of the articles. Before using the articles, please ensure the latest revisions are being used, as the articles are updated on an as-required basis by the writer and given new revision numbers.

Citroen Classic Owners' Club of Australia: [Technical Articles](#)

Citroen Car Club of Victoria: [Tech Tips](#)

1. 2CV 40-Litre Fuel Tank
2. 2CV API GL-4 Gearbox Oil
3. 2CV Battery Charging Circuit
4. 2CV Battery Problems Solved
5. 2CV Brake Saga
6. 2CV Buyer's Questions
7. 2CV Carburettor Cover Screws
8. 2CV Carburettor Jets and Adjustments
9. 2CV Dim-Dip Headlights
10. 2CV Engine Problems
11. 2CV Fuel Filter
12. 2CV Fuel Gauge and Battery Meter
13. 2CV Gearbox Output Hubs
14. 2CV Gearbox Unwinding Debacle
15. 2CV Hard Luck Stories
16. 2CV Headlights and Rear Lights Improvement
17. 2CV Ignition Coil
18. 2CV Knife Edges Replacement
19. 2CV Low Oil Pressure Beeper and Lights On Beeper
20. 2CV Maintenance - Part 1 of 2
21. 2CV Maintenance - Part 2 of 2
22. 2CV Oil Breather
23. 2CV Oils and Maintenance Advice From Burton Car Company
24. 2CV Points Ignition Reinstallation
25. 2CV Roof Rack
26. 2CV Secondary Choke Butterfly Adjustment
27. 2CV Spare Parts to Carry
28. 2CV Valve Clearance Adjustment
29. 2CV Workshop
30. Better Fuel Hose Clamps – **applies to all vehicles**
31. Better UHF CB Car Radio Performance – **applies to all vehicles**
32. Ignition Coil Ballast Resistors – **applies to all vehicles**

## FINAL STATEMENT

This article may be updated in the future and assigned a new revision number. Please download the latest revision before using the information in this article.

My acknowledgement and grateful appreciation is given to the web sites from which photos/drawings/diagrams have been sourced.

If material copyrighted by others has been inadvertently used in this document without permission, then upon receiving advice, the writer will remove the material immediately.

If you have questions about the information in this article, if you find errors or incorrect statements, if you have suggestions for improvement, or should you wish to republish this article in your club magazine, please - contact the writer at: [gdennes@gmail.com](mailto:gdennes@gmail.com)

The hosting or republishing of this article without the formal consent of the writer is not authorised and will constitute an infringement of Copyright Law.

Copyright © Graeme Dennes 2021, 2025