

# 2CV HANDBRAKE ADJUSTMENT

Revision 1



Graeme Dennes

# 2CV HANDBRAKE ADJUSTMENT

Revision 1

Graeme Dennes

## Background

The Citroën 2CV Repair Manual 8161, Vol. 1, October 1983 describes the procedure to adjust the handbrake on vehicles fitted with front drum brakes on page 127 and for vehicles fitted with front disc brakes on page 128. This article expands on Citroen's handbrake adjustment procedure for front disc brakes. For information, the pages 127 and 128 of the repair manual are included in the Appendix of this article. (The procedure for front drum brakes on page 127 is self-explanatory and won't be discussed here.)

The Citroen repair manual states that when the handbrake is correctly adjusted, the front wheels begin to tighten when the handbrake is pulled out to the third notch, and the wheels are locked when it reaches the fifth notch.

Note the handbrake should not be pulled out *more* than five notches or clicks, else it will be in danger of being withdrawn too far. Should this happen, intervention will be required to release the handbrake to allow the vehicle to be driven away! On the other hand, if it pulls out *less* than five clicks, it may result in unnecessary wear of the handbrake pads when the handbrake is off. Five clicks is the magic number! No more. No less.

## Handbrake Components on Brake Caliper:

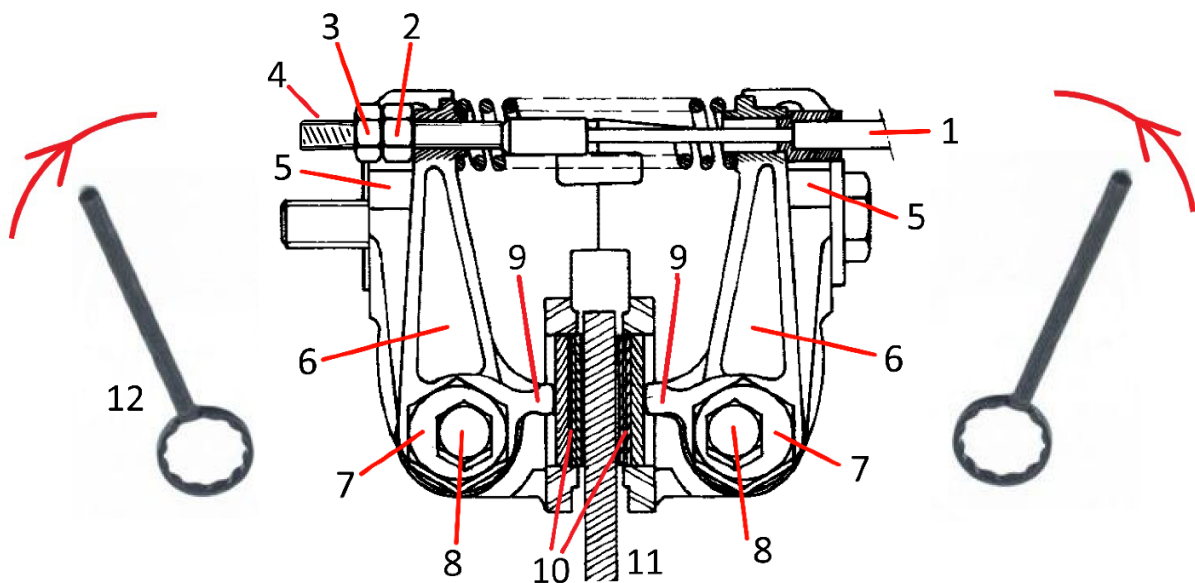

*Fig. 1 Handbrake components*

Numbered Items in Fig. 1:

- |                                              |                                  |
|----------------------------------------------|----------------------------------|
| 1. Handbrake cable                           | 7. Eccentric x 2                 |
| 2. Handbrake cable adjuster nut              | 8. Eccentric locking bolt x 2    |
| 3. Handbrake cable adjuster lock nut         | 9. Actuator x 2 (part of item 6) |
| 4. Outer threaded section of handbrake cable | 10. Handbrake pad x 2            |
| 5. Actuating arm end stop x 2                | 11. Brake Disc                   |
| 6. Actuating arm x 2                         | 12. Eccentric Adjusting Tool     |



Fig. 2 Eccentric and Eccentric Locking Bolt

Fig. 3 Eccentric

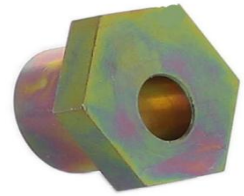

Fig. 4 Set of 2CV handbrake pads. The metal backing plates measure 30 mm in diameter.



Fig. 5 Actuating arm. The actuator pushes the handbrake pad against the brake disc.

Figs. 2 and 3 show handbrake eccentrics (7) and eccentric locking bolt (8). The offset (cam) arrangement of the eccentrics may be observed.

Fig. 4 shows a set of four handbrake pads. Two are fitted to each brake assembly.

Fig. 5 shows a handbrake actuating arm (6) and actuator (9). The handbrake cable passes through the opening in the top of the arm. The eccentric fits through the larger opening in the bottom of the arm, and the eccentric locking bolt passes through the off-centre hole in the eccentric, securing the actuating arm and locking the eccentric to the caliper.

Referring to Fig. 1, when the handbrake is applied, the handbrake cable draws the upper ends of the actuating arms closer together (they form a floating, self-centring assembly), which in turn causes the actuators to apply equal pressures to the handbrake pads, which in turn apply equal pressures to each side of the disc, locking the disc and the wheel.

### Handbrake Adjustment:

Citroen designed the handbrake in the 2CV to be adjusted in two steps – a coarse adjustment and a fine adjustment.

1. The **coarse** adjustment is done by the eccentrics, achieved by positioning the eccentrics so the handbrake pads *just touch the disc*.
2. The **fine** adjustment is done by the cable adjuster nuts. This is done by turning the cable adjuster nuts equally so when the handbrake is pulled out to the third click, the wheels begin to tighten, and at the fifth click, the wheels are firmly locked.

Let's do it.

## Handbrake Adjustment Procedure for Disc-Brake Vehicles

### Initial steps:

- a. Chock the rear wheels.
- b. Place the gear lever in Neutral.
- c. Release the handbrake.
- d. Lift the front of the chassis so both front wheels are off the ground. Fit jack stands.
- e. For easier access, remove the flexible heating tubes, the air filter assembly and, optionally, the heat exchangers.

### Coarse adjustment by the eccentrics:

- a. Loosen the handbrake cable adjuster lock nut (3).
- b. Loosen the handbrake cable adjuster nut (2) to allow the actuating arms to fully rest against their end stops (5).
- c. Loosen the eccentric locking bolts.
- d. Using the eccentric adjusting tool (12), turn the eccentrics until the actuating arms are positioned *furthest away from the disc*. (You'll observe the actuating arms moving to the left or the right as the eccentrics are turned.)
- e. Ensure the actuating arms are fully resting against their end stops.
- f. Using the eccentric adjusting tool, turn the eccentrics in opposing directions as indicated by the red arrows in Fig. 1 (the left eccentric is turned *clockwise*, and the right eccentric is turned *anticlockwise*) so both actuating arms move *towards* the disc until the handbrake pads *just touch the disc with the lightest touch*. You will feel this. This must be done at the position of maximum disc runout for each eccentric.
- g. Tighten the eccentric locking bolts, ensuring the eccentrics do not turn while tightening. A thin smear of copper grease on the outer face of the eccentrics (under the head of the locking bolts) will often assist the tightening process.
- h. Repeat steps a to g for the other wheel.

### Fine adjustment by the cable adjuster nuts:

- a. Position the cable adjuster nuts on the brake cables by hand until the *lengths* of the outer threaded sections (4) are the same (ignoring the lock nuts). This ensures the brake cables are correctly balanced. Apply and release the handbrake several times to assist (but don't pull out more than five clicks!).
- b. While turning the wheels by hand, alternately tighten the cable adjuster nuts *by equal amounts* (say six flats/one full turn each) until both wheels begin to tighten when the handbrake is pulled out three clicks, and the wheels are locked at the fifth click. Should a cable rotate when the adjuster nut is turned, fit an adjustable spanner to the flat outer end of the cable to prevent it turning. When adjusted correctly, the handbrake should pull out five clicks. No more. No less. Apply and release the handbrake several times to check.
- c. Tighten the cable adjuster lock nuts.
- d. Replace the item(s) removed at the initial steps.
- e. All done.

Describes the handbrake adjustment for front drum brakes.

OPERATION No. A. 454-0 : *Adjusting the handbrake*  
(Vehicles fitted with drum brakes)

Op. A. 454-0

1

### ADJUSTING THE HANDBRAKE

PL. 478

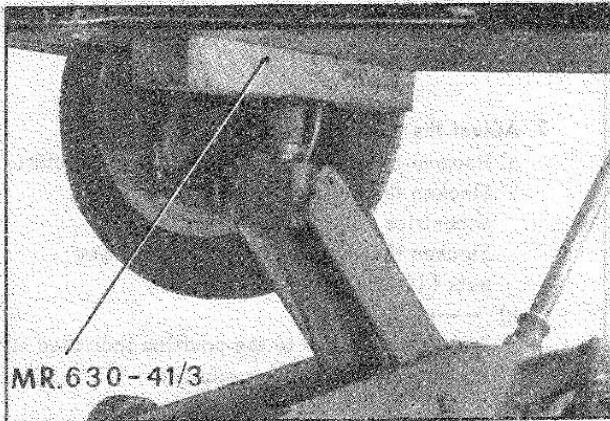

NOTE : The handbrake operates the front brake drums only.

1. Raise the front part of the vehicle using support MR. 630-41/3 on a mobile jack.

PL. 518

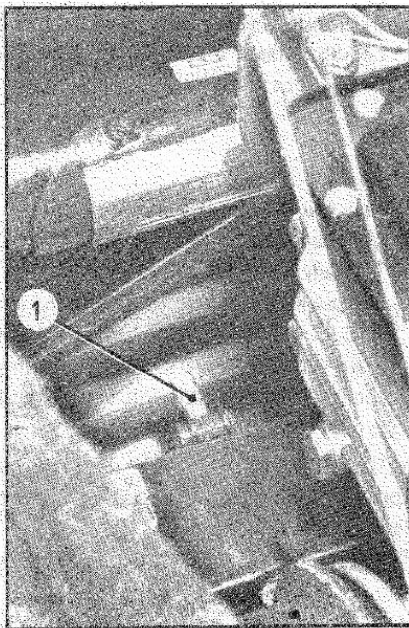

2. Adjust the tension of both brake cables in turn, using the nuts ( 1 ) so that the wheels begin to tighten when the brake handle is raised to the third notch, and when it has reached the fifth notch, the wheels are locked.

Describes the handbrake adjustment for front disc brakes.

2

**OPERATION No. A. 454-0 : Adjusting the handbrake**  
( Vehicles fitted with disc brakes )

**ADJUSTING THE HANDBRAKE**

The handbrake controls four pads which act upon the front brake discs. It is completely independent from the main brake.

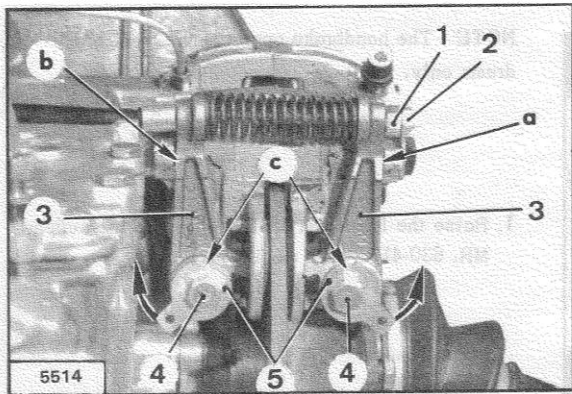

1. Raise the front part of the vehicle and place it on stands. Push the parking brake handle fully in.

**2. Adjust the eccentrics :**

a) Remove the flexible ducts for heating system. Slacken the securing screws (4) of the eccentrics (5). Slacken the lock nuts (2) and adjusting nuts (1).

b)  $\rightarrow$  6/71 :

Set the eccentrics to the position indicated on the photo ( slots « c » upwards ).

6/71  $\rightarrow$  :

Set the eccentrics to the position allowing maximum clearance ( spanner 2115-T ).

Make sure that the arms (3) are on their stops at « a » and « b ».

c) Turn eccentric (5) in the direction indicated by the arrow until the pads just come in touch with the disc. This adjustment must be carried out at the point of maximum run-out ( turn the disc by actuating the corresponding wheel ).

d) Tighten the securing screws (4) to 4 da Nm ( 28.88 ft.lbs ), making sure that the eccentrics do not turn while tightening.

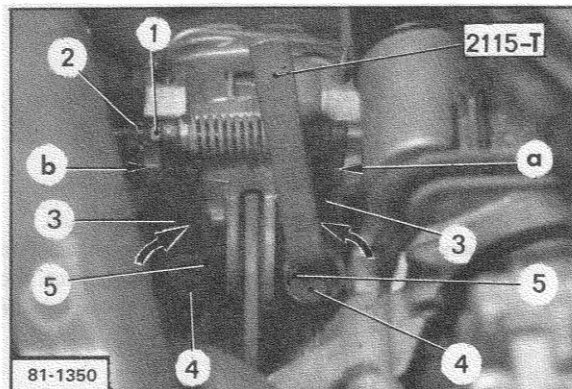

**3. Adjust the handbrake cable :**

a) Make sure that the sheath ends (7) and the sheaths (6) are correctly positioned.

b) Successively turn the right-hand and left-hand nuts (1) so that the wheels begin to tighten when the brake handle is raised to the third notch and they are locked when the fifth notch has been reached.

NOTE : The lengths « d » of the cable threads must be approximately the same on the right and left hand sides ( within 5 mm ( 0.19 in ).

Tighten the lock nuts (2) to 1.5 daNm ( 10.83 ft.lbs ).

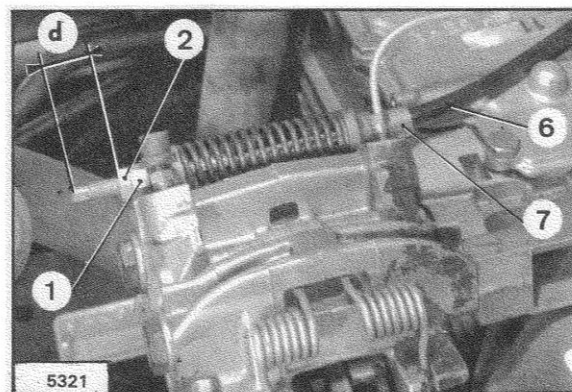

**4. Check the hand brake :**

Make sure that the handbrake does not work loose when raised to locking position.

Operate the control lever several times, ensuring that the adjustment does not vary.

5. Lower the car to the ground.

## LIST OF ARTICLES BY THE WRITER

The articles written by the writer, listed below, may be freely downloaded from either of the following club websites by clicking on the adjacent links and locating the articles. Both websites maintain the latest revisions of the articles. Before using the articles, please ensure the latest revisions are being used, as the articles are updated on an as-required basis by the writer and given new revision numbers.

Citroen Classic Owners' Club of Australia: [Technical Articles](#)

Citroen Car Club of Victoria: [Tech Tips](#)

1. 2CV 40-Litre Fuel Tank
2. 2CV API GL-4 Gearbox Oil
3. 2CV Battery Charging Circuit
4. 2CV Battery Problems Solved
5. 2CV Brake Saga
6. 2CV Buyer's Questions
7. 2CV Carburettor Cover Screws
8. 2CV Carburettor Jets and Adjustments
9. 2CV Dim-Dip Headlights
10. 2CV Engine Problems
11. 2CV Fuel Filter
12. 2CV Fuel Gauge and Battery Meter
13. 2CV Gearbox Output Hubs
14. 2CV Gearbox Unwinding Debacle
15. 2CV Handbrake Adjustment
16. 2CV Hard Luck Stories
17. 2CV Headlights and Rear Lights Improvement
18. 2CV Ignition Coil
19. 2CV Knife Edges Replacement
20. 2CV Low Oil Pressure Beeper and Lights On Beeper
21. 2CV Maintenance - Part 1 of 2
22. 2CV Maintenance - Part 2 of 2
23. 2CV Oil Breather
24. 2CV Oils and Maintenance Advice From Burton Car Company
25. 2CV Points Ignition Reinstallation
26. 2CV Roof Rack
27. 2CV Secondary Choke Butterfly Adjustment
28. 2CV Spare Parts to Carry
29. 2CV Valve Clearance Adjustment
30. 2CV Workshop
31. Better Fuel Hose Clamps – **applies to all vehicles**
32. Better UHF CB Car Radio Performance – **applies to all vehicles**
33. Ignition Coil Ballast Resistors – **applies to all vehicles**

## FINAL STATEMENT

This article may be updated in the future and assigned a new revision number. Please download the latest revision before using the information in this article.

My acknowledgement and grateful appreciation is given to Automobiles Citroën for the use of the two handbrake adjustment pages.

My acknowledgement and grateful appreciation is given to the web sites from which photos/drawings/diagrams have been sourced.

If material copyrighted by others has been inadvertently used in this document without permission, then upon receiving advice, the writer will remove the material immediately.

If you have questions about the information in this article, if you find errors or incorrect statements, if you have suggestions for improvement, or should you wish to republish this article in your club magazine, please - contact the writer at: [gdennes@gmail.com](mailto:gdennes@gmail.com)

The hosting or republishing of this article without the formal consent of the writer is not authorised and will constitute an infringement of Copyright.

Copyright © Graeme Dennes 2026