

2CV MAINTENANCE
PART 1 OF 2
Revision 29



Somewhere on Raid Arnhem 2016. Ouch!!
(Well, at least the colours match...!)

Graeme Dennes

2CV MAINTENANCE - PART 1 OF 2

Revision 29

Graeme Dennes

Before using the information in this article, ensure the latest revision is being used.

Section	Page	Subject
1	3	Servicing
2	6	Brakes
3	20	Clutch
4	24	Electrical
5	42	Engine
6	49	List of Articles by the writer

This article is accompanied by its associated article:

2CV MAINTENANCE - PART 2 OF 2.

1. SERVICING

Recommended Annual Servicing Steps:

1. Set valve clearances to 0.2 mm when engine is cold. The feeler gauge should be a firmish sliding fit between the valve stem and the rocker arm.
2. Change spark plugs, but *only* when engine is cold. Set gap to 0.7 mm.
3. Change engine oil and oil filter.
4. Change fuel filter.
5. Clean carburettor small mesh filter. Ensure not damaged. (Don't damage it when refitting!)
6. Clean air filter with turps then squeeze a little foam filter oil or engine oil through the filter element. Remember, it's the oil that traps the dirt. The foam element is simply the carrier for the oil. Clean more often depending on conditions.
7. Grease kingpins, drive shafts and knife edges with a high-shock-loading grease such as Castrol Spheerol LMM. *Do this with the wheels off the ground.* You may choose to grease kingpins more than once per year depending upon kilometres driven and road conditions driven on. There is a view held by some 2CV owners that the knife edges should not be greased, but rather, be kept clean and free of grease, with perhaps a spray of dry lubricant added to the rolling surfaces.
8. If points are fitted, set points gap or dwell angle, then set timing with a strobe timing light at 800–850 RPM. Easiest of all? Install an electronic ignition unit, set the timing once then promptly forget all about it! This improves reliability and removes a maintenance task.
9. When engine has warmed up, adjust idle speed and idle mixture at 800–850 RPM for a smooth idle.
10. Adjust handbrake for five “clicks” when fully activated. More follows.
11. Check/set vehicle height. More follows.
12. Check clutch cable is correctly adjusted. Set for 5 mm of free play at the pedal rubber.
13. Check brake pedal is correctly adjusted. Set for 5 mm of free play at the pedal rubber.
14. Check throttle cable is correctly adjusted.
15. Check choke cable is correctly adjusted and the choke plate is fully vertical (“off”) when the choke is pushed fully in.
16. Disconnect, thoroughly clean and reconnect all cabling at the battery terminals. Ensure battery, posts, terminals, battery tray and firewall areas are clean of corrosion.
17. Ensure starter motor and alternator wiring connections are clean and tight.
18. Inspect the integrity and security of the fuel line components between the fuel tank and the carburettor. Rubber hoses should be soft and pliable. If a rubber hose shows signs of wear, stiffening, cracking or splitting, replace it *urgently*. Use *fuel* hose with an inside diameter of 5.5 mm (7/32”). Use hose clips which do not damage the rubber, such as the stainless steel ABA Mini 12/9W4.
19. Ensure the engine's air tubes are correctly positioned and supported. Ensure they can't come into contact with hot exhaust components.
20. Inspect the integrity of the three engine/gearbox mounts – two at the front of the engine below the fan cowling and one at the rear of the gearbox. These are critical to safety, and any wear or looseness should be addressed *immediately!*

Other Recommended Service Steps:

1. If ignition points are fitted, replace points and capacitor every two years.
2. Change gearbox oil every two years with vehicle sitting on level ground. After filling, allow all excess oil to drain/drip from the filler port. *Do not overfill!*
3. If your 2CV has disc brakes at the front, replace the LHM brake fluid every three to four years. LHM fluid is not hygroscopic.
4. If your 2CV has drum brakes at the front, replace the DOT brake fluid every two years. DOT fluid is hygroscopic.
5. Replace spark plug leads every three to four years. Treat them gently! If possible, use cable ties to locate them to stop them being moved around by vibration or air flow.
6. Adjust drum brakes every three years.
7. Replace rubber fuel hoses every five years, including the hose at the fuel tank. It's also an opportunity to remove the fuel tank and flush any water and dirt out of the tank.
8. Replace fuel pump diaphragm every five years.
9. Replace the grease in the steering track-rod end ball joints every five years with a high-shock-loading grease such as Castrol Spherol LMM.

Cleaning the Air Filter:

Use mineral turpentine to wash and clean the foam rubber air filter element. Mineral turpentine is oil-based and is the best product to clean foam filters because it is 100% safe for the foam filter and the adhesive used to join the ends. The use of petrol will eventually soften the adhesive and affect the foam rubber. Use it in an emergency, but prolonged use will cause the foam to swell and the adhesive in the join to become brittle and break. Rinse again in fresh turps to flush any remaining dirt out of the filter.

Changing Spark Plugs:

If changing spark plugs, do so only when the engine is cold. Er, why...? The coefficient of thermal expansion of the steel spark plug base is around half that of the aluminium alloy used for the engine heads.

And the problem is...?

If a spark plug is fitted and correctly tightened when the engine is hot, then as the engine cools, the aluminium head socket shrinks faster than the steel spark plug base.

And the result? The aluminium head socket tightens itself in a death grip around the spark plug base, forcing the mating threads to become more deeply enmeshed. This causes an axial tensioning on the spark plug base which attempts to draw the plug body deeper into the head, producing a result identical to a very much over-tightened spark plug!

And the consequence is? The spark plug will be **very much harder** to remove next time. Further, the (softer) aluminium head material of the socket may suffer thread damage from metal being removed, and you definitely won't want that to happen to your engine.

Should you find a spark plug which is **difficult to remove** when the engine is cold, take the vehicle for a run to warm it up and try again when hot. The safest way? Remove and replace spark plugs **ONLY** when the engine is cold. Dead cold. Don't risk the damage.

Adding Gearbox Oil:

Before adding gearbox oil to the 2CV, it is important that the vehicle is sitting on level ground. Add oil to the oil filler port until it *just* overflows, then allow it to stand long enough so *all excess oil* can drain out / drip out of the port to the very last drop before refitting the oil filler plug. Too much oil in the gearbox can cause difficulties in engaging gears because the synchromesh may be rendered inoperative. (Haynes Manual, page 76).

Note that Citroën's specified tightening torque for the *gearbox oil filler plug* is only about one-third of the torque specified for the *gearbox drain plug*!

Copper Grease:

Apply a *thin* layer of copper grease to the threads of bolts and studs before assembly and tightening. They are much easier to remove next time. Be careful not to over-tighten.

Multi-Use Rocker Cover Gaskets:



Fig. 1-1

The writer uses the rocker cover gaskets from Burton which are made from a soft pliable rubber. The gaskets fit around the edges of the rocker covers. See Fig. 1-1 at left courtesy of Burton, showing the gasket cross-section. These can be reused multiple times and provide a much better seal than the standard gaskets. Further, these gaskets are fitted without adhesive, making them much easier to remove, clean and refit compared to the standard gaskets. The Burton part number for this gasket is A1.5319.

Refitting the Rocker Covers:

When refitting the rocker covers with these gaskets fitted, hold the rocker cover in place and seat the nut by hand. Then tighten the nut a further **one and one-half turns as specified by Burton**, and also as specified by Burton in the YouTube video at:

Burton 2CV Parts - Rocker Cover Gasket 2CV. Because of the type of rubber used in these Burton-manufactured gaskets, Burton's intention is for it to be fitted with low nut tension. This not only extends the life of the gaskets, but it also prevents deformation of the rocker covers! Yes, a long-lasting, perfect solution! Run the engine for a couple of minutes and check that no oil leaks are occurring around the gaskets or rocker covers. Top up the engine oil.

Why 2CV Spark Plugs Are Changed Annually:

The 2CV engine uses the "wasted spark" ignition system, where the ignition coil fires *both* spark plugs on *every* turn of the crankshaft (the spark plugs are connected in series electrically). When the spark plugs fire, one cylinder is at the top of its compression stroke and the fuel mixture is ignited, while the other cylinder is at the top of its exhaust stroke and the spark is unused (wasted). Thus the term "wasted spark" ignition. This is employed because it does away with the need for a distributor. Because of this arrangement, 2CV spark plugs have half the operating life of those used in standard four-stroke engines because they are fired twice as often.

2. BRAKES

Replacing Brake Master Cylinder Reservoir Seals:

To remove the brake master cylinder fluid reservoir, gently roll it to one side, continuing until it separates from the master cylinder. Do not attempt to remove it vertically else damage to the reservoir may occur. Remove and discard the two reservoir seals. While the reservoir is removed, give it a thorough cleaning inside and out.

To fit new master cylinder reservoir seals, firstly dip the seals into fresh brake fluid (LHM or DOT as applicable), then insert and press the seals into the master cylinder openings until the seals are flush against the upper metal faces of the master cylinder. This ensures the seals are correctly locked in place in the master cylinder. The writer found that hexagonal-topped seals are easier to work with than round-topped seals.

Then apply a little brake fluid to the spigots on the bottom of the reservoir. With the reservoir lying 45° to one side, place the spigots in contact with the seals, then commence pressing/pushing the reservoir spigots into the seal openings while moving the reservoir slowly towards its vertical aiming position. Take your time. When the spigots are correctly seated and locked in place below the seals, the base of the reservoir should be nominally flush with the upper faces of the seals, confirming the spigots have reached through to the bottom of the seals.

Fill up the reservoir with fresh brake fluid. Bleed the brakes to expel all the old fluid and air bubbles. Top up the reservoir. All done!

Never Reuse brake line seals and brake caliper seals:

Whenever brake lines have been disconnected *for any reason whatsoever*, always replace the rubber seals when reconnecting them – every time! *NEVER reuse the old seals* – if you wish to ensure leak-free fittings! If a seal has been compressed/deformed *once – for however long*, discard it. It's very cheap insurance against fluid leaks.

Also, if the calipers have been removed from the vehicle, always replace the small O-ring between the caliper halves - every time! If the pistons have been removed from the calipers, always fit new pressure and dust seals to the calipers - every time!

Replacement of Brake Caliper Piston Seals

Replacement of brake caliper pistons and seals. Sometimes a piston can be difficult to remove from the caliper housing, so in preparation for the task, with the calipers *still in situ and brake fluid lines still attached*, remove the four brake pads from the calipers. Then firmly activate the foot brake pedal several times, which should drive the pistons outwards to where they come into contact with the brake discs. A mirror and light will confirm if the four pistons have contacted the discs. If one proves stubborn and is not in contact with the brake disc, activate the brake pedal several more times with more passion! It should get the job done! (Compressed air also works – using great care!)

The calipers are then removed from the vehicle. Carefully mark each caliper half so the same caliper halves can later be returned as a pair to the same side of the vehicle.

The calipers are then separated into their two halves, exposing the pistons. Remove the pistons using a brake caliper piston removal tool. The tips will “bite” onto the inside face of the piston and allow it to be withdrawn when rotating the piston with the tool. The piston seals will become visible. The inside diameter of the pistons is about 32 mm.

After removing the old seals from their grooves – *be very careful not to score the groove surfaces*, thoroughly clean the insides of the piston spaces, ensuring absolutely no dirt or foreign bodies remain in the piston space, inside the piston grooves or in the fluid orifices. A compressed air nozzle will assist.

There are two LHM rubber seals fitted in the grooves of each caliper half and these seals are different. Both seals are in contact with the piston. Refer to Fig. 2-3 below.

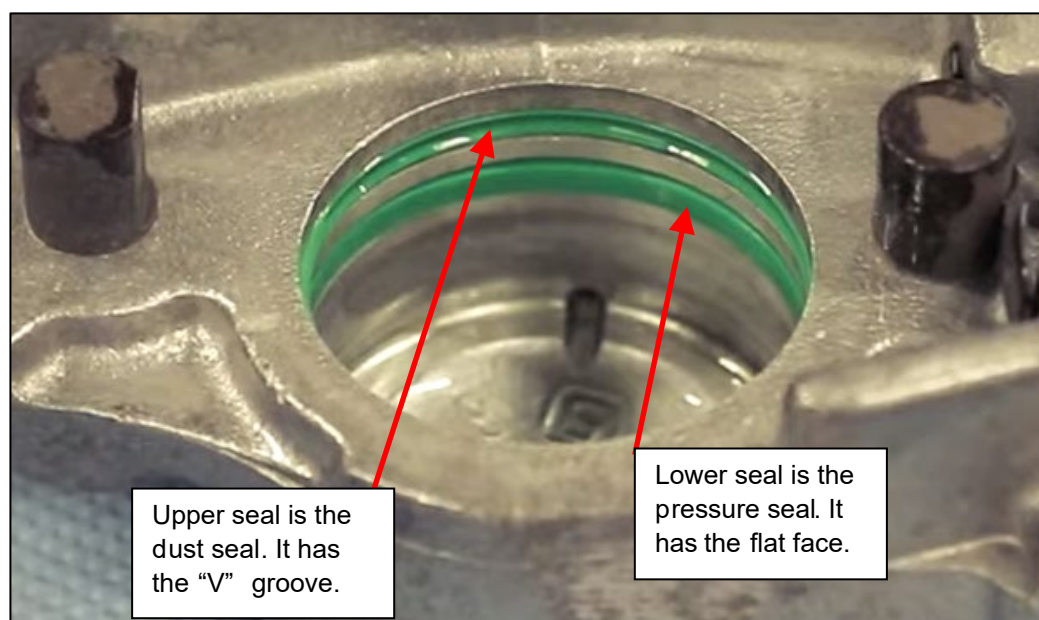

Fig. 2-3 Brake Caliper Piston Seals

In Fig. 2-3, the lower seal is the pressure seal, which is flat on its inside face, while the upper seal is the dust seal, which has a “V” groove on its inside face. Check and then recheck that the seals are fitted as shown above after making sure the fluid paths are clear.

Note: Burton and Der Franzose have recently made changes to the composition of the rubber seals in their disc brake repair kits because of defective materials used in some previous kits which allowed (guaranteed!) brake fluid leaks! In the improved kits, the lower (pressure) seal for the pistons and the small O-ring seal between the caliper halves are coloured black, signifying the improved items. The upper (dust) seal remains green in colour. Other manufacturers may also have made this change. Black is the current colour of the improved parts, but the colour of the seals could change in the future.

When ready to fit the new piston seals in the caliper grooves, liberally coat the grooves, the inside of the piston housing and the new seals with LHM fluid and *very gently* guide the seals into their respective grooves. Don't use any force whatsoever or the seals may be damaged and cause a fluid leak! The seals will easily and comfortably drop into place in the grooves once they are lined up correctly. Ensure the seals are fully seated in their grooves and flush with the inner face of the piston space. We don't want the seals to be damaged when the piston is fitted. If the seals don't want to lie flush within their grooves, which will prevent the piston from being fitted, take both seals out, roll them over the lubricated outside face of a piston to expand them slightly, then return them to the grooves and retry. They should fit flush in the grooves.

Liberally coat all surfaces of the seals with LHM fluid. Take the piston (the current or new piston) and coat the outside and bottom face with LHM fluid. Position the piston with the open end facing upwards, then rotate and press the base of the piston gently into its opening in the caliper half, keeping the piston properly lined up (not skewed). Rotate the piston gently by hand until it comes into contact with the seals, then using the brake caliper piston removal tool, *very carefully* rotate the piston, while at the same time, pressing gently on the piston until its rounded lower edge slides over the first and then the second rubber seal. Continue pressing the piston by hand until its outside edge is flush with the caliper face.

If the piston seems to be unable to "get past" the seals, remove the piston and the seals and stretch the seals slightly as already described. If need be, keep them stretched this way for several minutes and repeat the steps. Keep everything clean, well lubricated with LHM fluid and do not hurry.

Repeat for the remaining piston, after which the caliper may be assembled and fitted.

When reassembling the caliper halves, always fit a new small O-ring seal, coated with LHM fluid, between the two caliper halves. Ensure this seal is not damaged during the assembly of the two halves, the fitting of the brake pad retaining clips and the fitting of the caliper to the gearbox. If it suffers damage in *any way* whatsoever, it will need to be replaced, otherwise a brake fluid leak from the caliper will be happening somewhere close to you! This small seal is usually included with the disc caliper repair kit to service one caliper unit. The writer attempted to buy the small seals separately but neither Burton nor Der Franzose could supply them. The only source for them was in the caliper repair kits. Why is this so?

After fitting the thin metal spacer between the caliper and the gearbox mounting face, tighten the two caliper mounting bolts to the specified torque. Repeat for other caliper. Refit the brake pads in each caliper *with the friction material against the disc!* Always ensure the inner ends of the pads are correctly located and the pads are securely held in place by the retaining clips. Use a mirror and light to check.

Reconnect the brake lines after fitting new seals. *Never reuse them.* Bleed the front brakes, then check that the four caliper pistons have moved outwards to make contact with the steel backing plates of the pads and the pads have been pushed flush up against the discs. Use a mirror and light to confirm all is well.

For information, Burton 2CV Parts presents a YouTube video on replacing the 2CV disc caliper seals. I encourage the reader to view this video if replacing the caliper seals in your 2CV. The video is shown at: [How to Recondition your Brake Calipers](#).

Brake Line Seal Removal Tool

Have you sometimes found it difficult to extract the old rubber brake line seals from their metal fixtures after the metal brake lines have been removed? The reason is because of the design of the seal and the end fitting on the brake line (the donut). This arrangement causes the seal to be compressed and “fatten” during the tightening of the nut on the brake line, forcing the rubber seal to fill the available space and close off the metal-to-metal connection between the metal brake line and the metal fixture. Because of this, the rubber seals can sometimes (most times?) be stubborn to remove. This is also the reason why we never reuse rubber seals because they have already spent their life being compressed in a unique manner. Once they’ve been removed from the fixture, discard them.

The writer decided to create the tool shown at Figs. 2-4 and 2-5 below. It started life as a small plastic-handled metal pick. The metal section is around 75 mm in length with a very sharp tip. Bend the tip into a small radius such that the folded end is able to be inserted into the opening of the brake seal. For the writer’s tool, **the sharp point of the tip is 4 mm from the folded end**. In operation, gently push the end of the tool into the centre of the seal and continue pushing until it reaches the end of its travel. Then, while pushing the sharp tip of the tool against the inner wall of the seal, withdraw the tool from the fixture. As the tool is withdrawn, the sharp tip bites into the rubber seal and removes the seal with it. After making and using this tool, you’ll wonder how you ever did without it!



Fig. 2-4



Fig. 2-5

Replacing Brake Line Seals:

Fig. 2-6 shows the rubber brake line seal 'a', the metal brake line 'b', the fluid opening 'c', the nut 'd' and the fixture 'e'. The brake line diameters at 1 and 3 are identical. The tip of the brake line at 4 is slightly smaller in diameter than at 3, and the brake line shoulder, situated between the diameters '3' and '4', rests against the fixture at the entrance to the opening 'c'. The expanded section at 2 is known as a 'donut' and pushes the seal 'a' against the fixture 'e'. Fig. 2-7 is an enlargement of the end section of the brake line shown in Fig. 2-6. Fig. 2-8 shows a brake line end with a seal fitted, ready to be inserted.

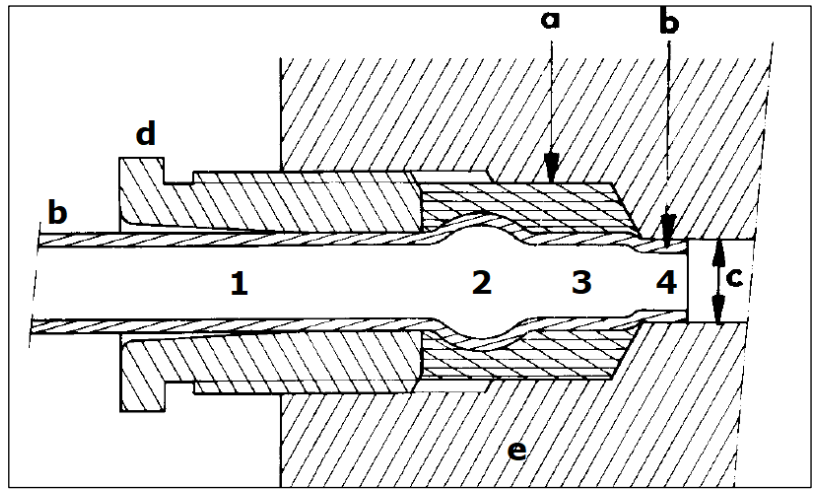

Fig. 2-6

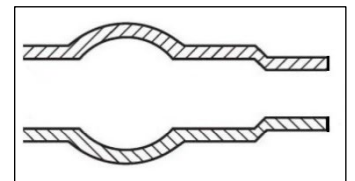

Fig. 2-7

Fit as follows:

- Add a wipe of brake fluid over the end section of the brake line.
- Dip a new rubber seal in brake fluid.
- Fit the seal onto the end of the brake line to a position where about 1 mm of the tip of the brake line is exposed as shown in Fig. 2-8.
- Gently insert the brake line and seal into the fixture, ensuring the tip 'b' enters the opening 'c'. You may feel the tip drop into the opening as you slightly move the brake line sideways while pushing it in. Continue gently pushing the brake line in by hand to where it will not enter any further. At this point, the brake line shoulder between diameters 3 and 4 should be contacting the entrance to opening 'c', as depicted in Fig. 2-6, and the seal is positioned correctly.

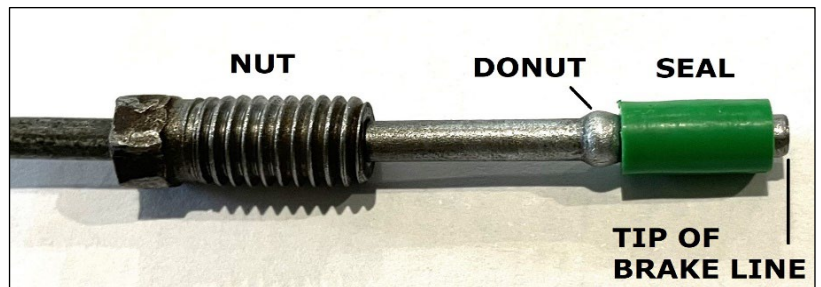

Fig. 2-8

- While holding the brake line in this seated position, screw in the nut 'd' *by hand until finger tight*. If the threads of the nut will not engage with the fixture, withdraw the brake line and seal, then move the seal a little closer to the tip, then repeat from step d.
 - Gently tighten the nut (**5.8 - 6.5 ft-lb**) to compress the seal so it expands sideways and closes off the space between the brake line and the fixture.
- Don't overtighten the nut.** Excessive force may cause the rubber seal to leak. It may also deform (damage) the metal brake line, guaranteeing a fluid leak! \$\$Ouch!
- Check for leaks after bleeding the brakes.

Rear Brake Line Union.

The rear brake line union, shown in Fig. 2-9 at right, connects the brake line from the brake master cylinder to the brake lines to the rear wheel cylinders. In the figure, the brake line at the left comes from the master cylinder, the brake line at upper left connects to the left rear wheel cylinder, and the brake line at upper right connects to the right rear wheel cylinder. The union is bolted to the bottom of the rear axle tube with the bolt shown, and sits just above the forward edge of the fuel tank. (Note that the fuel tank has to be removed to gain access to the union.)



Fig. 2-9 Rear Brake Line Union

The brake lines leading to the rear wheel cylinders pass from the union, into openings in the rear axle tube (partially showing in the figure), along the inside of the axle tube, exiting the axle tube at the rear suspension arm bearings, then follow the suspension arms to the wheel cylinders. (Fig. 2-9 was taken after the writer had replaced the brake line between the brake master cylinder and the union. The originally fitted (1974) brake line had corroded through from the inside and produced a fluid leak in the line about a metre from the master cylinder. BTW, the red colour in the figure is not rust. It's Raid Cape York dust!

Brake Master Cylinder and Fluid Reservoir:

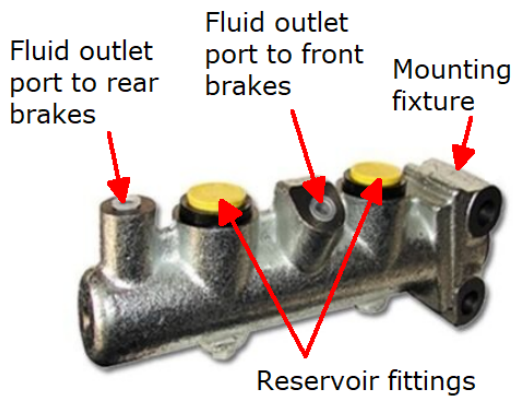

Fig. 2-10 2CV Dual-Circuit Brake Master Cylinder



Fig. 2-11 2CV Brake Fluid Reservoir

The 2CV brake master cylinders are made at several global manufacturing sites by several global manufacturers. They are not all identical to Fig. 2-10. Further, the specifics of their internal design, components and operation may differ to those discussed in the following. Therefore, what follows should only be used as an in-principle guide to your own master cylinder.

2CV Foot Pedal and Master Cylinder Assembly:

Fig. 2-12 shows the foot pedals on the left, the activating pushrod in the centre, and the master cylinder on the right. All items are removed from inside of the vehicle!

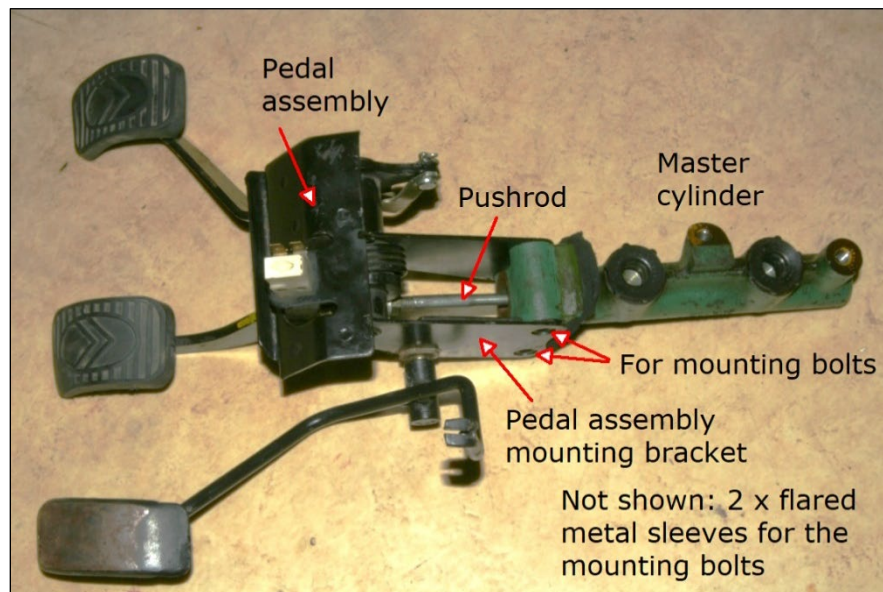

Fig. 2-12 Pedals and master cylinder (Courtesy of Norbert Heinz)

In Fig. 2-12, the pedal assembly and the master cylinder are both secured in place in the vehicle firewall by two bolts with metal sleeves. The bolts pass through the pedal assembly mounting brackets (shown) and the master cylinder mounting fixture (also shown in Fig. 2-10). Also shown are the attachment points for the clutch and accelerator cables on the respective pedals, as well as the brake light switch.

Dual-Circuit Hydraulic Braking Systems:

Dual-circuit hydraulic braking systems were introduced to vehicles in the 1960s, and essentially all manufacturers had incorporated dual-circuit brakes into their vehicles by 1970. In operation, the brake master cylinder controls two independent brake fluid circuits. In the 2CV, the front brakes are operated by one hydraulic circuit and the rear brakes by the other. Dual-circuit systems are also known as tandem or split systems.

Why do we have them? Redundancy and safety. Should one circuit fail, the other circuit is able to brake the vehicle, albeit with a lower pedal position and much reduced stopping power. The logic? Partial braking is very much better than no braking and is the *raison d'être* for the dual-circuit master cylinder's existence. The subject here is safety.

Fault Diagnosis of Dual-Circuit Braking System:

Sometimes the brakes can be found to be less than ideal. The pedal may feel somewhat spongy. Perhaps the pedal goes down too far. As there's a single footbrake operating two independent braking circuits, then to diagnose problems, it can be advantageous to check each braking circuit in isolation from the other. This is done by disconnecting the other brake circuit, as follows.

To check the front disc brake circuit in isolation, the rear drum brakes need to be temporarily disconnected. Disconnect the **front-most brake line** from the master cylinder and plug the outlet port with an M8 x 1.25 bleed nipple. The brake pedal will then be operating the front disc brakes only.

Similarly, to check the rear drum brake circuit in isolation, the front disc brakes need to be temporarily disabled. Disconnect the **rear-most brake line** from the master cylinder and plug the outlet port with an M8 x 1.25 bleed nipple. The brake pedal will be operating the rear drum brakes only.

After completing the repair work, reconnect both brake lines to the master cylinder and perform the usual brake bleeding operation.

Brake Master Cylinder Operation:

Two pistons, two springs, two roll pins and four rubber cup seals form the master cylinder internal components, per Figs. 2-13 and 2-14 below. Fig. 2-14 shows the physical arrangement of the cup seals, the pistons and the springs.

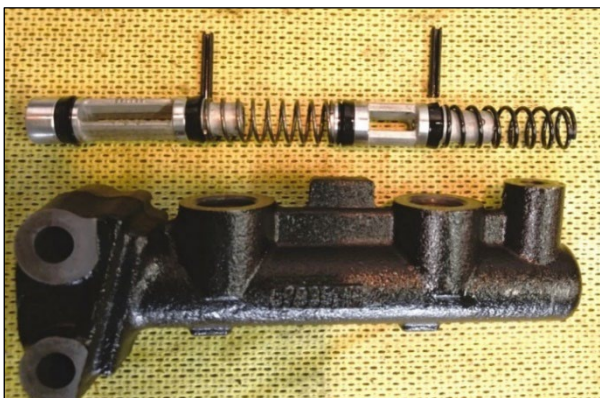

Fig. 2-13 Master cylinder internal components (Courtesy of John Wyers)

The piston on the left is the primary piston, which is activated by the brake pedal pushrod. The piston on the right is the secondary piston. Each piston is fitted with a rubber cup seal at each end to seal off the fluid in the pressure chambers in front of the pistons where the springs are located. *The chamber holding the primary spring is the primary chamber, which feeds fluid to the front disc brakes, and the chamber holding the secondary spring is the secondary chamber, which feeds fluid to the rear drum brakes.* The secondary spring is the heavier of the two.

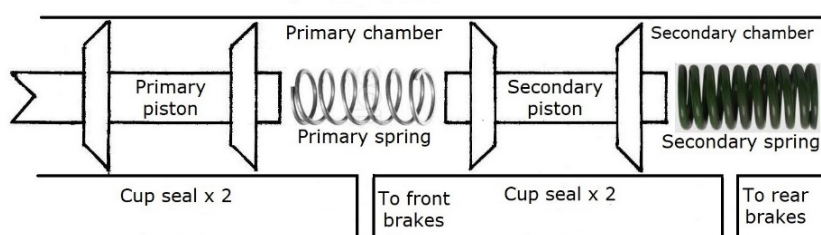

Fig. 2-14 Internal component arrangements

Note that Fig. 2-14 does not include the fluid orifices *inside* the master cylinder nor the fluid orifices to the reservoir, as the design for these varies, as will the *detailed explanation* of their operation!

When braking, the brake pedal pushrod pushes on the primary piston, forcing it forward. No hydraulic pressure is created until the front seal on the primary piston moves past the compensating (or vent) port from the reservoir, but once it does, fluid is trapped in the primary chamber between the two pistons, and it becomes a solid column, hydraulically coupling the two pistons. The solid fluid column occurs early because the primary spring is lighter than the secondary spring as already noted, so the solid fluid column in the primary chamber starts to be pressured, which feeds to the front brakes.

At that moment, the primary piston, the solid fluid column between the pistons and the secondary piston are acting as a single, “solid” structure, moving forward together as one, as the brake pedal continues to be applied. (No braking has occurred to this time.)

As the brake pedal is further applied, the front seal on the secondary piston is pushed past its compensating port, so the fluid ahead of the secondary piston, in the secondary chamber, starts to be pressured, which connects to the rear brakes. *At that moment, the fluid in front of both pistons, i.e., in both chambers, starts being pressured.* As the brake pedal is pushed further, the secondary piston continues to move forward, pushing fluid to the rear brakes, causing the clearances at the brake shoes to be taken up. Once the rear brake shoes contact the drums, the secondary piston starts acting against an increasing resistance from the rear brakes, greatly slowing the secondary piston’s forward movement as the rear brakes just start to be applied.

At that very same moment, the primary piston feels the resistance from the secondary piston via the solid fluid column, and so pressure starts to build on the primary piston,

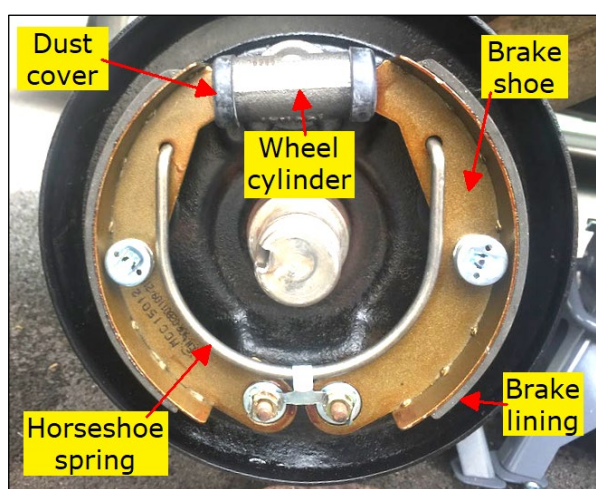

Fig. 2-15 Rear Brakes

which the foot starts to feel, as pressure starts being applied to the front discs (and the rear drums). By this means, the fluid braking pressure increases to the front and rear brakes together, and the front and rear brakes act jointly to slow the vehicle.

When the foot is lifted off the brake pedal, the master cylinder pistons are returned back to their resting positions by the two springs, and the rear brake horseshoe spring (shown in Fig. 2-15) returns the brake shoes and the wheel cylinder pistons back to their resting positions, which pushes the (now) excess fluid trapped in the wheel cylinders back to the master cylinder and the reservoir, ready for the next brake pedal application.

Bench Bleeding the Brake Master Cylinder:

(Sounds a little like “The brunette bride that brainwashed the Brigadier”, with apologies to The Sketch Show).

Before fitting a master cylinder to the vehicle, the master cylinder should be bench bled before being fitted to the vehicle. Whaaaaat? Why? To remove **all** air trapped inside it. Um, isn’t the air inside the master cylinder removed during the normal brake bleeding operation? Well, it ain’t necessarily so!

Why Do We Bench Bleed?

Perhaps you’ve experienced a slightly softish/spongy brake pedal that can never be corrected, no matter how many times you’ve bled the brakes or how many litres(!) of brake fluid you’ve pumped through the brake system? Perhaps you’ve experienced the need to apply two pumps of the brake pedal to firm up the brakes? Perhaps the pedal travel is a little excessive?

These are the usual symptoms of air trapped inside the master cylinder fluid passages which is not removed during the normal brake bleeding operation due to the angle at which the master cylinder sits when in the vehicle. To add to the displeasure, **the trapped air typically can't be forced out with brake pedal pressure alone during a normal bleed.**

With the rear brake shoes correctly adjusted and with the brake pedal pushrod adjusted for 5 mm of free play at the pedal rubber, you should start to feel the brake pedal pressure almost immediately the pedal is pushed, and the pedal travel to reach the maximum braking position should be quite small. If not, the master cylinder has air trapped inside!

Once you've experienced the feel of the brake pedal with a *thoroughly* purged master cylinder, you will never forget the response! You'll wonder how you've done without it!

*Requiring two pumps of the brake pedal can also be caused by faulty dust covers on the rear wheel brake cylinders. Refer to the section: **Two Pumps to Firm Up the Brake Pedal.***

With air permanently trapped inside the master cylinder, your brake pedal can **never** achieve its intended operation and feel, and you'll be relegated to driving with a non-optimum braking system which may not stop your vehicle as quickly as it should. The purpose of bench bleeding is to expel **all** the air trapped inside the master cylinder!

What follows cannot be easily done with the master cylinder fitted to the vehicle, so it needs to be done with the master cylinder on the work bench. Thus the term, "bench bleed". To remove the master cylinder from the vehicle, firstly disconnect the clutch and accelerator cables from the pedals, then remove the fluid reservoir and reservoir seals, then disconnect the two metal brake lines. Remove the two bolts and nuts securing the pedal assembly and master cylinder to the firewall, then remove the assembly from inside the vehicle. Don't discard the removed reservoir seals at this time. Ensure the reservoir is **thoroughly** clean before commencing the procedure. We don't want any dirt contamination in the brake system!

Note: This procedure presumes the rubber cup seals inside the master cylinder are in a sound operating condition. If not, or if in doubt, replace the seals before continuing. It's cheap insurance!

The *thorough* bench bleeding procedure:

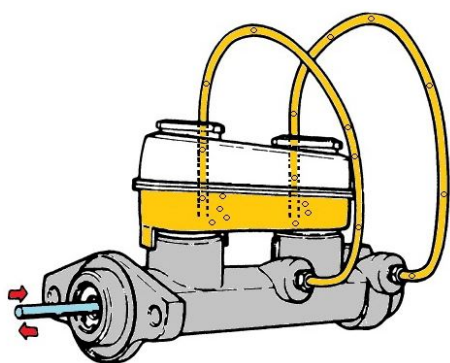

Fig. 2-16 Bench bleeding arrangement

a. Place the master cylinder securely in a **soft-jawed** vice, clamped by the side faces of the mounting fixture (indicated in Fig. 2-9), with the master cylinder in a horizontal, normal-way-up position. Don't clamp the master cylinder by the body (to prevent possible deformation). **Check the body is horizontal using a spirit level.**

b. Temporarily fit the **old** reservoir seals.

c. Temporarily fit the reservoir, with the spigots inserted perhaps half-way into the seals. Doesn't need to be any further.

d. Construct the arrangement portrayed in Fig. 2-16, adapting as necessary. The writer used the cut-off end sections and nuts from two old brake line sections (cut to about 75 mm in length, per Fig. 2-8) to connect to the fluid outlet ports.

The other ends of the brake lines are fitted with small-diameter clear vinyl tubing of sufficient length to allow the tube ends to be directed into the top of the reservoir and reach the bottom of the reservoir, and of a diameter to ensure a tight seal is made with the brake lines. If necessary, use electrical tape to hold the two tubes in place in the reservoir. The clear tubing enable any bubbles expelled from the master cylinder to be observed.

- e. Add sufficient fresh brake fluid to the reservoir so both tanks contain fluid. Don't let the reservoir run dry!
- f. A tool is needed to hand-operate the master cylinder pistons. The most forgiving tool is a wooden dowel of around 8 mm diameter with a rounded end. **Don't use a metal tool with a sharp or pointy tip** like a screwdriver or punch that could slip and scratch the bore walls of the master cylinder, promoting fluid leaks and premature wear of the internal rubber seals.
- g. Using the wooden dowel, **slowly** push and **slowly** release the piston inside the open end of the master cylinder (the "pushing" end). In Fig. 2-16, the pushing end is on the left, with the wooden dowel is coloured blue. Ensure the dowel is gently pushed in until slight resistance is felt at the end of its travel. Don't push it any further than that. You will observe brake fluid and air being expelled from the master cylinder fluid outlet ports and back into the reservoir through the clear tubes.
- h. **Wait 10 seconds between each push** of the piston to allow the low-pressure chambers to release all the air and fill completely with fluid.
- i. Repeat steps g and h until no further air bubbles are observed in the tubes.
- j. Loosen the vice and raise the pushing end of the master cylinder so the body centreline is angled upwards by around **5 to 10°** and relock the vice.
- k. Repeat steps g and h until no further air bubbles are coming from the master cylinder. Between pushes, a few light taps with a screwdriver handle can help the bubbles exit.
- l. Loosen the vice and lower the pushing end of the master cylinder so the body centreline is angled downwards by around **5-10°** and relock the vice.
- m. Repeat steps g and h until no further air bubbles are coming from the master cylinder. Between pushes, give a few light taps with the screwdriver handle.
- n. **Repeat steps j to m** until no further air bubbles are coming from the master cylinder. Take your time and don't be in a rush to finish this. You want it done right!
- o. Finally, loosen the vice and **return the master cylinder to the horizontal position** and relock the vice after checking with the spirit level. Repeat the steps g to h until no further air is seen passing through the vinyl tubes.
- p. This completes the bench bleeding procedure. The air has been purged!
- q. **Don't remove the master cylinder from the vice.**
- r. Syphon the brake fluid from the reservoir until it's as empty as possible.
- s. With a collection container or rag placed under the master cylinder, carefully *remove the reservoir from the reservoir seals by rolling it to one side. Then remove the reservoir seals, then remove the metal brake lines (and tubing) from the master cylinder. Don't remove the fluid sitting in the top of the reservoir ports. We don't want air entering the master cylinder!*
- t. After wiping the external faces of the master cylinder as cleanly as possible, temporarily place duct tape over both brake line outlet ports and over both reservoir ports to prevent fluid loss. *Again, don't remove the fluid sitting in the top of the reservoir ports.*

- u. Keeping the master cylinder upright and horizontal, **remove the master cylinder from the vice**. Fit the pedal assembly brackets to the master cylinder using the flared spacer sleeves. Flare open both sleeve ends. The sleeves will hold the entire assembly together while the master cylinder is gently and carefully fitted back through the firewall, still keeping it as upright and as horizontal as possible. Fit the two master cylinder mounting bolts, washers and nuts to secure the master cylinder and the pedal assembly in position in the firewall fixture. Two pairs of hands can assist.
- v. Remove the duct tape from the brake line outlet ports and screw the vehicle brake lines into the master cylinder with **new** rubber seals fitted after dipping them in fresh brake fluid. *The rearward fluid outlet port connects to the front brakes and the forward fluid outlet port connects to the rear brakes.* Tighten them carefully to prevent damage to the metal brake lines.
- w. Dip two **new** reservoir seals into fresh brake fluid, remove the duct tape from the reservoir ports and carefully and firmly insert the seals into the reservoir ports until they are fully seated and locked in place in the master cylinder. *Again, don't remove the brake fluid sitting in the top of the reservoir ports!*
- x. Dip the reservoir spigots in fresh brake fluid, then fit the reservoir into the reservoir seals, pushing the spigots in from say 45° from vertical, then rolling the reservoir slowly towards vertical while pushing the spigots down into the seals and locking the bottom lips of the spigots under the bottom edges of the reservoir seals. When correct, the reservoir should be sitting *vertically* in the master cylinder.
- y. Add fresh brake fluid to the reservoir to its full mark, then perform the usual brake bleeding process to expel all air in the brake system. Bleed the left rear wheel first, the right rear wheel second, then the front calipers last. Don't let the reservoir run dry!
- z. Top up the reservoir to its maximum level mark. Don't overfill. All done.

Conclusion:

Why do we go through such a tedious process with bench bleeding? Because we want to do everything in our power to remove the last vestige of air from inside the master cylinder, and there's no magic wand to achieve this. *We can only do everything possible!* Still, it needs to be done only once!

Two Pumps to Firm Up the Brake Pedal:

Have you experienced the need to apply two pumps on the brake pedal to fully firm up the brakes, and where the brake pedal doesn't go down as far on the second pump? The writer recently found a response by Ken Hanna [here](#) in a 2014 Pembleton web forum thread discussing this issue. (The Pembleton is a kit car which uses 2CV mechanicals.)

Refer also to [Bench Bleeding the Brake Master Cylinder](#) for a similar symptom.

In a nutshell, some of the (then) commercially-available rear wheel cylinders were being supplied with **rubber dust covers which are of the wrong shape**. This causes the wheel cylinder pistons to be pulled back into the cylinder, opening up a gap between the pistons and the brake shoes (these normally remain in contact with each other). Part of the first brake pedal pump closes up the gap between the wheel cylinder pistons and the shoes. The (immediate) second pump doesn't require as much movement of the pistons, thus the brake pedal stroke on the second pump is a little less, but nonetheless, still taking two pedal pumps to fully firm up the brakes.

A visual inspection of the wheel cylinders with the brake drums removed will show the pistons being pulled back into the wheel cylinders between brake operations because of the shape of the dust covers, causing the pistons to lose contact with the brake shoes.

Ken Hanna reports: “The first time I encountered these incorrectly shaped dust covers was as far back as 1995 and it's disappointing that the message has never got back to the manufacturers, or if it has, that they've never bothered to correct their error. The problem is not that the rubber of the dust covers is stiffer, it's that the covers are of the wrong shape, so the pistons are pulled back into the cylinder and out of contact with the shoes”.

Ken states that one solution to the dilemma of being unable to obtain the correct dust covers is to fit a spring *inside* the wheel cylinders between the internal faces of the pistons so as to apply a small force to keep the pistons in contact with the shoes.

[Writer's note: Fitting a random spring inside the rear wheel cylinder could result in scoring of the bore wall, unless it was held centrally in the bore by some means. The preferred solution is to replace the dust covers or the entire wheel cylinders – so long as the dust cover problem has since been corrected.]

Is It Safe to Drive With a Spongy Brake Pedal?

Without putting too fine a point on it: NO! Spongy brakes are a dangerous problem for motor vehicles and is indicative of a deeper problem. If your brake pedal feels spongy, your vehicle is not safe to drive. Identify and repair the underlying issue as quickly as possible. Most importantly, soft or spongy brakes prevent you from stopping as quickly as you would otherwise. In a word? Dangerous.

Brake Adjustments:

The front disc brakes are self-adjusting, and the brake pads are always in contact with the discs, thus there is no fluid transferred to the front brakes when the brakes are applied. The rear drum brakes, on the other hand, need to have the brake shoes adjusted periodically, and the shoes are slightly pulled away from the drums by the horseshoe springs when the brakes are released.

Because of this, when the brakes are initially applied, a small volume of fluid is pushed to the rear brakes from the master cylinder's secondary (front) chamber, which pushes the wheel cylinder pistons outwards. As the pistons are *always in contact with the brake shoes*, the brake shoes are pushed into contact with the drums, after which the brakes at all four wheels start to be applied. When the brakes are released, the horseshoe springs pull the brake shoes slightly away from the drums, which in turn pushes the wheel cylinder pistons back into the wheel cylinders, which in turn pushes the excess fluid in the wheel cylinders back to the master cylinder and the reservoir, ready for the next brake pedal application.

Brake Pedal Clearance Adjustment:

Be wary of setting insufficient free clearance at the brake pedal pushrod which operates the brake master cylinder. Citroen states the pushrod should be adjusted to achieve **5 mm** of free play at the brake pedal rubber. (See the Specifications section.) If it's less than that figure on disc-braked cars, the front brakes could end up being slightly applied, which will cause them to heat up, expanding the LHM fluid and bring the vehicle to a halt!

Some Parts used by the writer:

These are offered as suggestions only. Available from various suppliers.

Set of disc brake pads. Burton PN A1.5708 or Der Franzose PN 13001.

Set of handbrake pads. Burton PN A1.5709 or Der Franzose PN 13055.

Disc brake caliper repair kit. Burton PN A1.5817 or Der Franzose 13019.

3. CLUTCH

Fit a new clutch?

Are you tired of the mandatory(!) take-off shudder-lurch-bugger bunny hops we can experience with our 2CVs? It's caused by the standard 2CV clutch plate not having torsion springs fitted between the clutch plate's friction surface (driven by the flywheel) and the splined central fitting (driving the gearbox shaft). The lack of torsion springs results in the take-off shudder we love to, er, endure! The shudder can be removed, thanks to advice from Elliot Beniada. Thank you Elliot.

The clutch shudder may be removed once and for all by fitting a diaphragm clutch in which the clutch plate is fitted with those marvellous torsion springs!! *However, a diaphragm clutch can only be fitted to the later 2CV flywheel, or a flywheel designed specifically for a diaphragm clutch, such as the flywheel from Burton A1.4321 or Der Franzose 10650.* In summary, a diaphragm clutch can only be fitted to a flywheel which is *designed and specified for use with a diaphragm clutch!* (The flywheel from the early 2CVs was not designed and specified for use with a diaphragm clutch.) More follows.

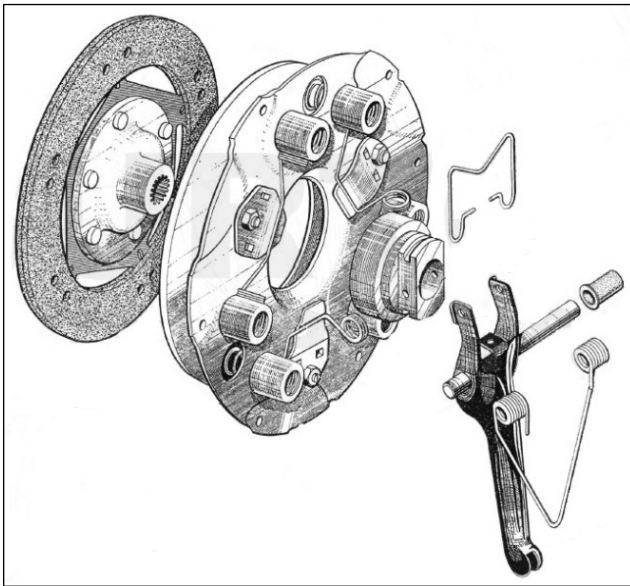

Fig. 3-1 The earlier (three-fingered) clutch

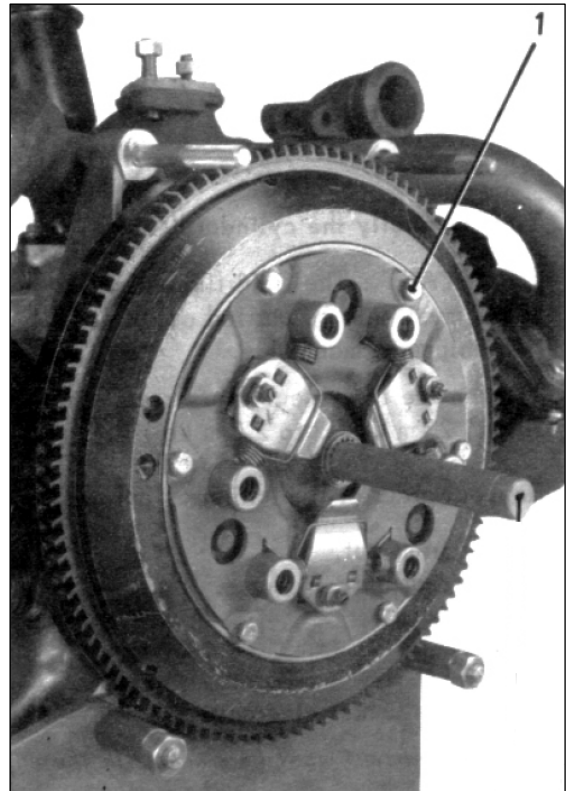

Fig. 3-2 The earlier (three-fingered) clutch

If your car was manufactured *before* February 1982, Citroën will have fitted a three-fingered clutch and a heavier flywheel. A diaphragm clutch *cannot be fitted to this flywheel.* In this case, you will need to purchase a post-1982 flywheel (which accepts the diaphragm clutch) to replace the original flywheel. The pre-February 1982 clutch assembly is shown at Figs. 3-1 and 3-2 above. Note the absence of torsion springs in the clutch plate.

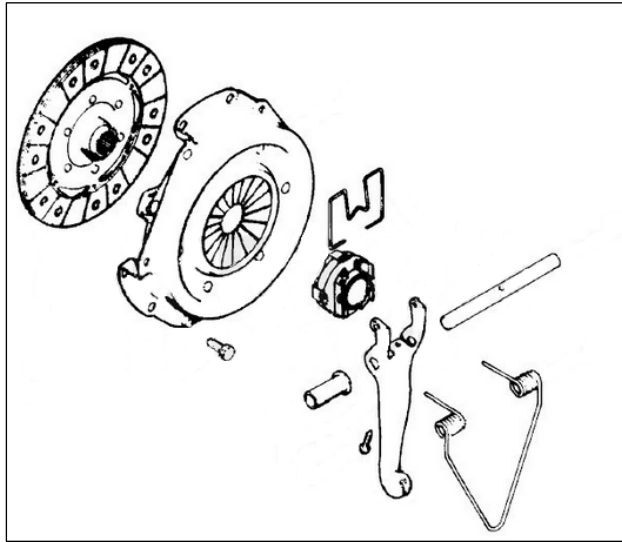

Fig. 3-3 The later (diaphragm) clutch

If your car was manufactured *after* February 1982, Citroën will have fitted a diaphragm clutch and the later (lighter) flywheel, in which case there is no need to purchase the lighter flywheel as you already have one! The new diaphragm clutch will fit your flywheel.

The post-February 1982 clutch assembly is shown at Fig. 3-3 on left. Again, note the absence of torsion springs in the clutch plate.

The writer understands that Citroën made the change from the three-fingered clutch (and heavier flywheel) to the diaphragm clutch (and lighter flywheel) at the same time as the front brakes were changed from drum brakes to disc brakes – in February 1982.



Fig. 3-4 The improved diaphragm clutch – fitted with torsion springs.

The converse is that if your 2CV has drum brakes at the front, it will also have the three-fingered clutch and the heavier flywheel.

To remove the clutch shudder, replace the clutch plate, pressure plate and thrust bearing with the items supplied in a clutch kit from Der Franzose with part number 10496 per Fig. 3-4 at left, courtesy of Der Franzose. The clutch plate in the kit is fitted with torsion springs like almost every other clutch plate on the planet. The six torsion springs are visible in the clutch plate.

The writer fitted these clutch kits to both his 2CVs at the same time as new engines were fitted. (A lighter flywheel had to be bought for the writer's orange car, a 1974 model, which was manufactured with the earlier three-fingered clutch, the earlier (heavier) flywheel and drum brakes at the front. It now has the improved diaphragm clutch, the lighter flywheel, disc brakes at the front, LHM fluid and LHM rubber seals throughout.

To summarise, *this clutch kit can only be fitted to the later, lighter flywheel (which accepts a diaphragm clutch)*, so if you have a pre-February 1982 car, it will have been manufactured with the heavier flywheel and the three-fingered clutch, so you will need to also purchase a lighter flywheel. (The point here is about *replacing* the earlier (heavier) flywheel with a later (lighter) flywheel, *not about attempting to machine the earlier flywheel to help it lose weight!!*). The torsion-spring clutch kit may also be available from other suppliers.

As a note, if fitting this clutch kit to your 2CV, then at the same time, you may also choose to replace the clutch cable, clutch fork, fork shaft, nylon bushes and fork spring.

Don't forget to order the *special* flywheel mounting bolts and the *special* pressure plate mounting bolts and lock washers. *Always replace these critical, sheer-loaded bolts as a matter of course. Never reuse them.*

Ensure the mating faces of the flywheel and the crankshaft flange are lightly hand-sanded and scrupulously clean before assembly. Don't lubricate the faces. Why go to so much bother? We absolutely don't want flywheel runout problems here! Tighten the flywheel bolts and pressure plate bolts *with a torque wrench to the settings specified by Citroën.*

So what was the result after fitting the new clutch kit? A completely different clutch/gear change feel, just like a modern vehicle. It provides a massively smooth, positive but gentle clutch action and super-smooth take-offs. Yes, utopia! No more shudder-lurch-bugger bunny hops across the car park! Crikey, I *almost* miss the shudder! Yeah, right!

Clutch Cable Replacement:

When fitting a new clutch cable, it is fitted at the clutch end first, then fed through to the clutch pedal.

Clutch Activation Components:

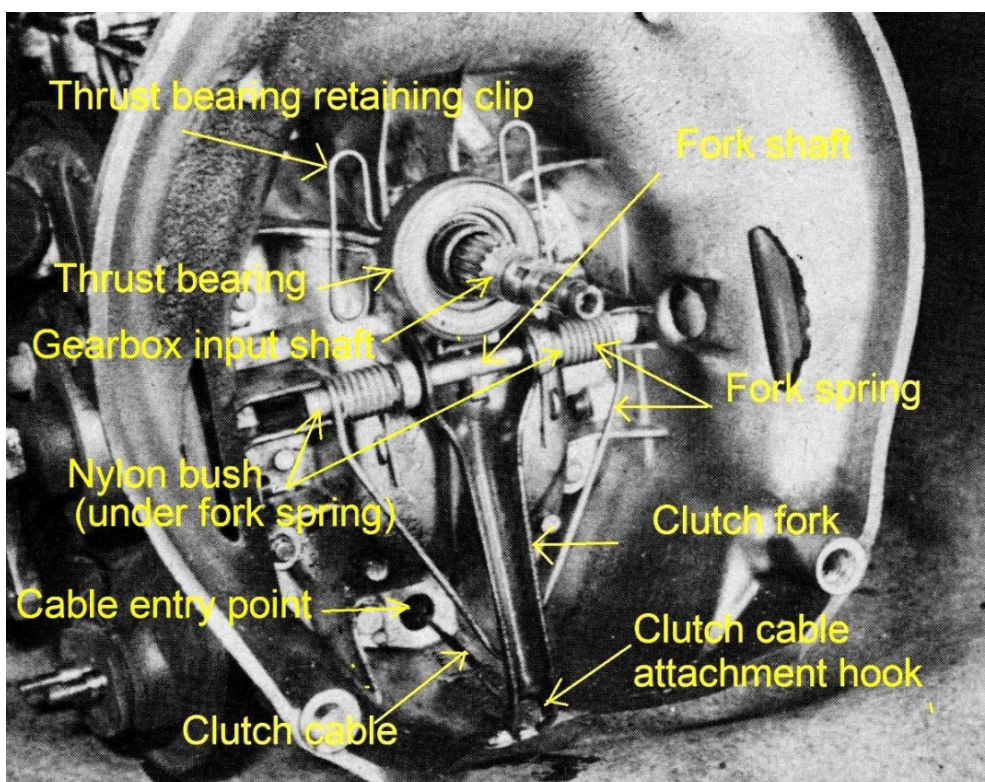

Fig. 3-5

Some Parts used by the writer:

These are offered as suggestions only. Available from various suppliers.

Diaphragm clutch kit with torsion springs. Der Franzose PN 10496. Comes with release bearing and retaining clip.

Clutch fork. Burton PN A1.3732 or Der Franzose PN 10081.

Fork shaft. Burton PN A1.3733 or Der Franzose PN 10386.

2 x Nylon bushes. Burton PN A1.3735 or Der Franzose PN 10185.

Fork spring. Burton PN A1.3734 or Der Franzose PN 10187.

6 x clutch pressure plate mounting bolts and spring washers. Der Franzose PN 10649 or Burton PN A5.0713 + PN A5.0707. Never reuse these sheer-loaded bolts. Use a torque wrench.

5 x Flywheel mounting bolts (no washers used). A chance to replace them. Burton PN A1.4319 or Der Franzose PN 10193. Never reuse these sheer-loaded bolts. Use a torque wrench.

Clutch cable RHD. Der Franzose PN 10688.

Clutch centring tool. Der Franzose PN 21054.

4. ELECTRICAL

Cleaning Electrical Connections:

Ensure the end caps of the electrical fuses and the fuse holders are spotlessly clean to provide a sound electrical connection. Ensure the fuse holder clips have a solid grip on the fuses, i.e. the fuses should not be loose. Bend the fuse holder clips slightly inwards if necessary. If a fuse holder clip show corrosion or burns, a repair will be needed. If the fuse end caps are loose or show corrosion or burns, replace the fuses.

We need to achieve *very* low-resistance connections here to prevent electrical problems. The writer sprays electrical contacts with the deoxidising contact cleaner INOX MX3. It removes corrosion, dirt and surface contaminants to give lasting protection from all forms of corrosion for all electrical components and equipment, greatly assisting conductivity. It doesn't dry out or wash off with water. For the writer, INOX is the "gold" standard contact cleaner.

Ensure all chassis grounded electrical wiring connectors are disassembled, wire-brushed and cleaned to remove oxides and corrosion products, then tightly reassembled. The cause of most electrical problems in the 2CV is high-resistance ground connections. Methodically attend to all ground connections this way, from the front bumper to the rear bumper! You are dealing with an old car. Again, INOX greatly assists by removing the oxidation and corrosion products.

Ensure all "bullet" electrical connectors, such as those used for the headlight wiring, are pulled apart, thoroughly brushed clean, the sockets pinched *slightly* tighter and then the two parts reconnected. You may choose to repeat the cleaning task every couple of years. It only takes a few minutes. Again, spray with INOX to improve the conductivity.

The "bullet" connections at the rear of the ignition switch and behind the instrument panel don't seem to require as much cleaning, no doubt because they are not in the engine bay where heat, dirt, moisture and airborne contaminants are the norm.

From this electronic engineer's perspective, these are poorly designed connectors for the task. Although the contact (surface) area is adequate, the spring force between the two contact faces is insufficient to ensure a good, low-resistance connection is achieved and maintained, so surface oxidation and surface corrosion are the norms for the 2CV, increasing the resistance of the connections over time. *Many* 2CV electrical problems can be traced back to the electrical connectors and their poor design.

We don't want contact resistances in our vehicles – anywhere, ever, but because vehicles use a range of wiring connector types, including crimp connections, joiners, plugs, sockets and terminations, then in practice, we just have to deal with the reality!

As noted elsewhere, our old cars are made up of old parts, and time, moisture, dirt, metal types and airborne chemicals conspire to produce contact resistance problems. All electrical connections in our older cars should be disconnected and cleaned every few years.

Corrosion and Electrical Systems

When it comes to vehicle electrical systems, many people shake their heads in despair. Even experienced mechanics can shy away from electrical work for fear of the unknown.

Corrosion is the biggest cause of failure in vehicle electrical systems. *Wires do not fail.* Ground connections and connectors (crimped, screwed, blade, socketed, etc) can become corroded and fail. Corrosion is electricity's biggest enemy. Failures with battery terminals, fuse blocks, wiring junction boxes, sensors and switches are also likely to be caused by corrosion.

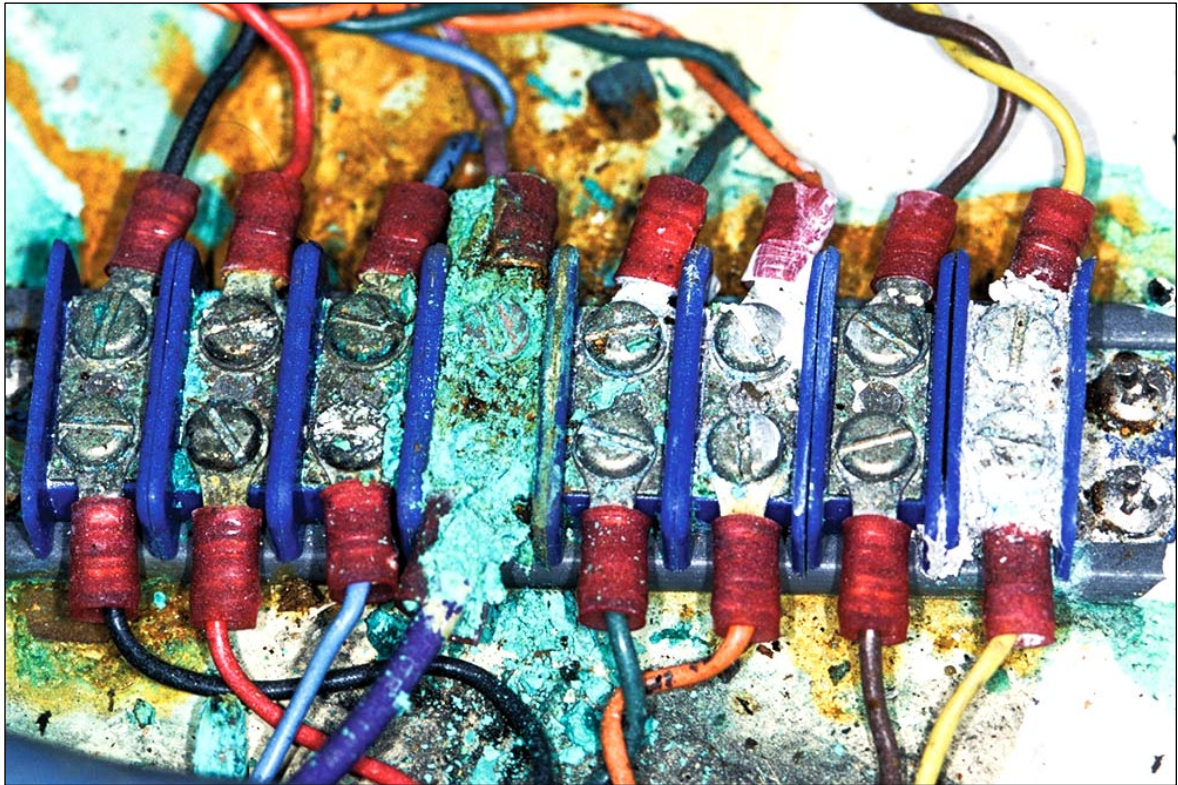

Fig. 4-1 Um... Say no more!

Cleaning or replacing electrical connectors will repair a great percentage of electrical problems. The engine bay is a savage environment for things electrical.

With most cars, the body/chassis is used as one of the 'wires' that feed each circuit or device. Usually, the body/chassis provides the negative side of the circuit, while the positive side of the circuit is fed by a wire. If a device is not properly connected to the body or chassis, or if the connection point is loose or corroded, the circuit is compromised by the addition of series resistances and will not function correctly. The first thing to do when a device or circuit fails is to make sure it has a proper ground connection.

As noted, *individual wires do not fail.* Insulation may crack and break off, but the (metallic) wire will still conduct electric current. *However, a wire can be caused to fail by subjecting it to excessive overload current (burned out), physical damage (crushing, cutting or severing), corrosion, excessive tension, repeated bending or repeated vibration.*

Yes, wires can fail, but only under conditions of extreme duress! Damage can usually be detected by following along the wiring loom and looking for cuts/damage. If the outside of the loom is not damaged, it is safe to assume the wires inside the loom are also not damaged.

Crimped connectors (all types) can fail, as well as their (pressure) connections with the attached wires. Sometimes the connectors break or loosen or corrode, or the wires become loose. Factory wiring looms usually do not have electrical connections hidden under tape or other wrappings, so when tracing a problem, follow the loom and verify that the connections at each wire exiting the loom are clean and functional. Crimped connectors can also fail due to poor quality materials or poor manufacture, or from the use of poor quality crimping tools or the incorrect use of the tools.

Switches, sensors and light bulbs are electrical components that are susceptible to failure. Components which produce heat or receive heat, those with moving parts or those that are exposed to water, dirt, fuels and oils are the most likely components to fail.

Most factory electrical systems, including the much-maligned Lucas systems, were carefully designed by experienced engineers. These work perfectly well until corrosion sets in or components fail.

Before troubleshooting a circuit, check and clean the battery terminals and check all fuses and fuse holders. Make sure the battery is fully charged. If a fuse has blown, do not replace it and think the problem is solved. The circuit(s) affected must be further tested to determine the cause of the blown fuse.

Fuses:



Fig. 4-2 Fuse holder and cover

In automotive electrical wiring (and home electrical wiring), the purpose of a fuse is to protect the circuit wiring, not the **device** being fed from the fuse. You may find a wire rated at say 20 amps being protected with a 20 amp fuse, feeding a device which draws perhaps two amps. The fuse is not incorrectly sized. The 20 amp fuse is there to protect the 20 amp wire, not the two amp device.

When adding a fused circuit, locate the fuse as *closely* as possible to the battery.

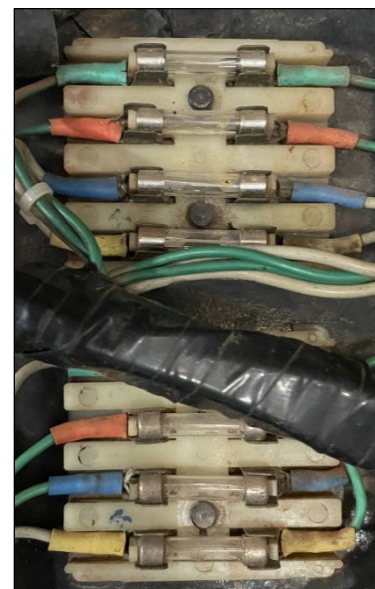

Fig. 4-3 Fuse holders and fuses

Starter Motor Currents:

A starter motor's *average* current while turning the engine is typically in the 200 to 300 amp range (2.4KW to 3.6KW), while its *peak* current, *just* before the engine starts to turn, a.k.a. locked rotor current, is usually 2-3 times its *average* current.

Citroen states the 2CV starter motor draws 150 amps during startup (1.8KW).

Headlight relays:

You may wish to consider fitting two relays – one to operate the low-beam filaments of the headlights and one to operate the high-beam filaments. Er, why? The light switch in the 2CV was not designed to supply the current used by modern headlight globes, which typically require five amps each with 65-watt globes. Two headlight globes will draw around 10 amps. This is a not-insignificant load current increase for a light switch designed for 45-watt globes and manufactured *at least* 30 years ago.

As an electronics engineer, the writer considers the 2CV light switch to be well-under-specified for the task, even when 45-watt globes were *de rigueur*. Contact resistance is a function of contact area, contact pressure, contact material and contact cleanliness. The resistance results in heat being generated at the (very old!) switch contacts.

Fitting headlight relays will supply the headlight current directly from the battery, taking the load away from the light switch, greatly reducing the heat generated at the switch contacts and extending the life of the switch.

After a drive with the headlights on, if the light switch feels warm (or hotter) to the touch, it's a clear indication of electrical stress caused by heat generated at the contacts because of contact resistance. The failure of the switch is well underway. Unfortunately, its internal design and construction offers little opportunity for making satisfactory repairs. Fit the relays now and extend the life of your light switch. An option is to fit LED headlight globes. These draw around 20 percent of the current the traditional incandescent or halogen globes draw, greatly lightening the load on the light switch and extending its life.

2CV LIGHT SWITCH OPERATION

Background:

Page 198 of the Haynes 2CV Owner's Workshop Manual (1990) shows the electrical wiring diagram for the 1987 2CV. It includes the wiring which terminates *at the five connection terminals on the light switch*. However, it does not show the *functional* operation of the light switch for the "O", "V" and "R" positions, nor does it show the *functional* operation of the two settings of the stalk switch.

2CV Light Switch:

A description of the operation of the 2CV light switch follows.

1. With the light switch in the "O" (off) position (fully anti-clockwise):

All vehicle lights are off.

2. With the switch in the "V" position (one position clockwise from off):

With stalk nearest the steering wheel:

Front parker lights on

Tail lights on

Instrument light on

With stalk furthest from steering wheel:

Low beam headlights on

Front parker lights on

Tail lights on

Instrument light on

3. With the switch in the "R" position (two positions clockwise from off):

With stalk nearest the steering wheel:

High beam headlights on

Front parker lights on

Tail lights on

Instrument light on

With stalk furthest from steering wheel:

Low beam headlights on

Front parker lights on

Tail lights on

Instrument light on

2CV Light Switch Internal Connection Diagram:

Lo = Low Beam
Hi = High Beam

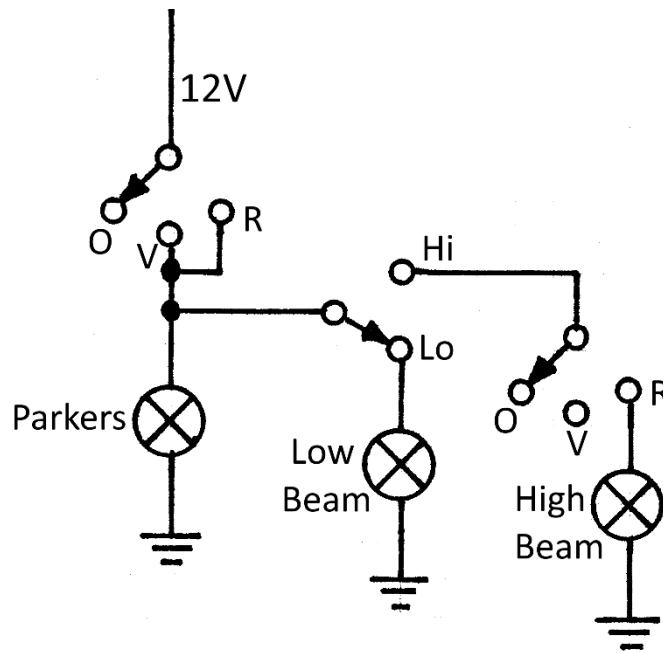

Fig. 4-4: 2CV Light Switch Functional Diagram

Fig. 4-4 shows the internal connection diagram of the 2CV light switch, excluding the horn. One connection terminal connects to the battery, one terminal connects to the parker lights, one connects to the low-beam lights and one connects to the high-beam lights.

In Figs. 4-4 to 4-6, the Parker lights comprise 2 x front parkers (2 x 4W), 2 x tail lights (2 x 5W) and the instrument light (1 x 2W).

The Five Light Switch Connection Terminals:

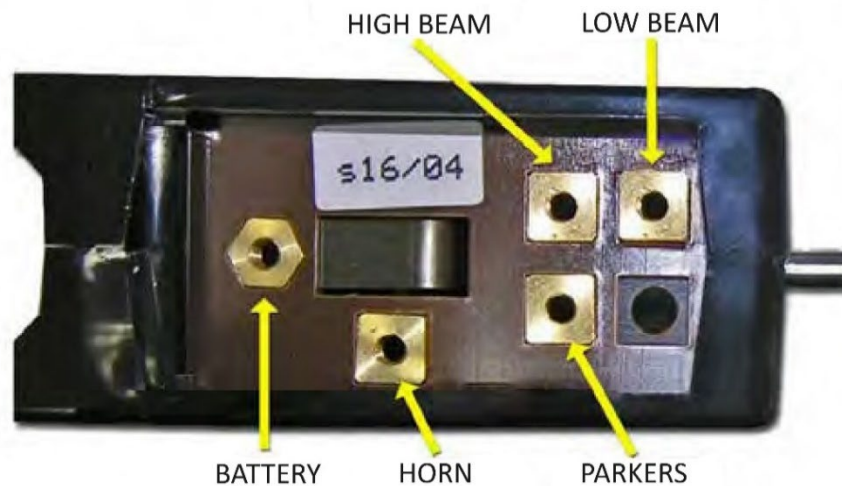

Fig. 4-5: 2CV Light Switch Connection Terminals

2CV Light Switch Wiring Terminals and Typical Colours:

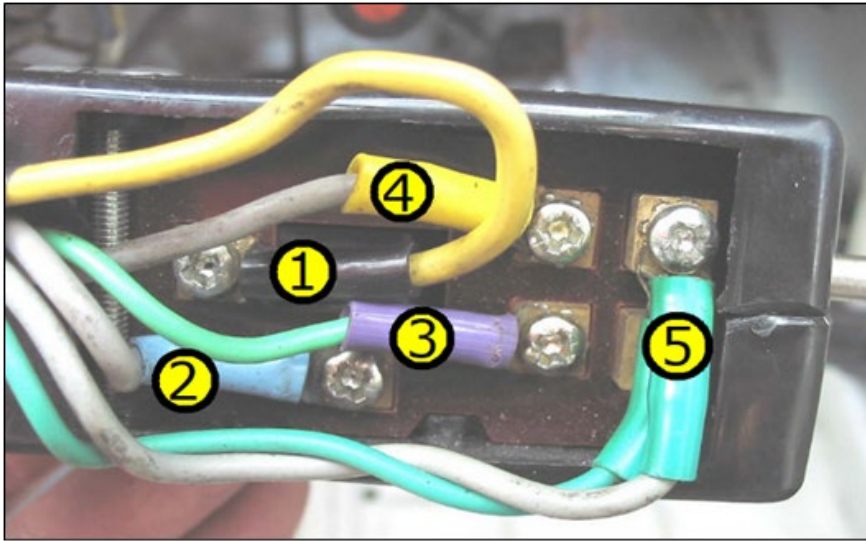

Fig. 4-6: Typical wiring colours. Yours may be different! (Thanks to Ken Hanna.)

In Fig. 4-6 above, note the wiring connections numbered 1 to 5:

- 1: To battery: yellow wire-black sleeve.
- 2: To horn: grey wire-blue sleeve
- 3: To parkers: green wire-lilac sleeve:
- 4: To high beam lights: grey wire-yellow sleeve:
- 5: To low beam lights: grey wire-green sleeve and green wire-green sleeve.

Star lock washers on Light Switch connection terminal:

The star lock washers on the light switch electrical connections in Fig. 4-6 are shown correctly fitted *underneath* the wire terminals to prevent the terminals rotating when the screws are tightened. This is known as “*French style*”. Plain washers should be fitted under the screw heads to protect the wire terminals – if the screws are long enough.

2CV Dim-Dip Lights Operation

Refer to the writer’s article, *2CV Dim-Dip Headlights* for a complete description of the operation of the dim-dip headlights arrangements, including wiring diagrams. The article also describes how to disable the dim-dip system to prevent further damage to the light switch. Dim-dip headlights were mandatory for all new UK cars over the 1987-88 period.

Standard 2CV Electrical Wiring Diagram From 1987:

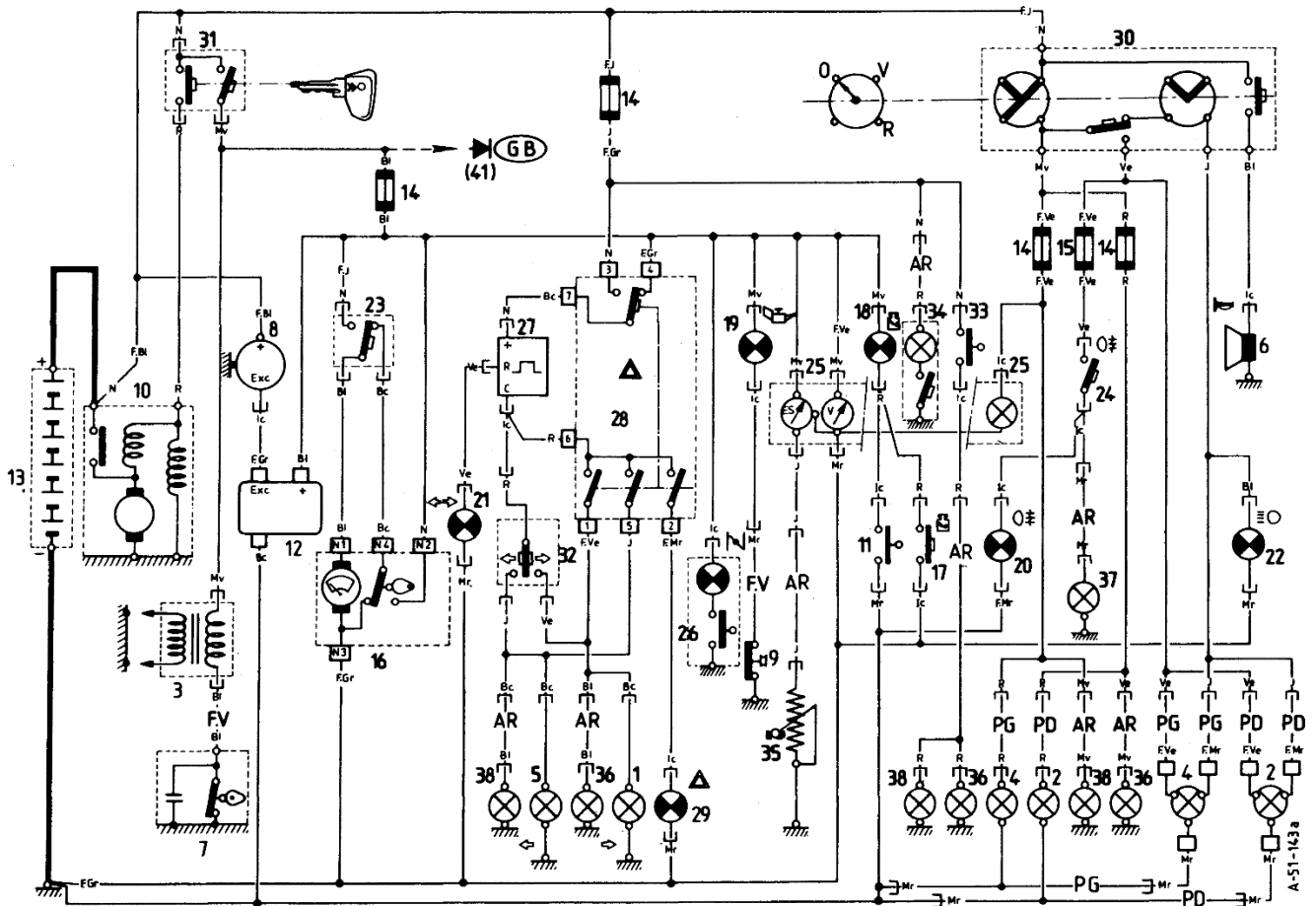

Fig. 4-5 1987 Standard 2CV Electrical Wiring Diagram
(From Haynes Manual (1990), page 198)

Starter Motor Solenoid (Relay):

When the ignition switch is turned to the “start” position, the ignition switch start contacts supply current from the battery to energize the starter motor solenoid, a relay, which in turn connects the starter motor to the battery via the heavy battery cables to start the engine. The current to energise the solenoid is several amps, a not-insignificant current for the ageing start contacts in the ignition switch. A better solution is to fit a relay which is activated by the ignition switch start contact, with the relay contacts supplying the current to operate the starter solenoid instead of it being supplied by the ignition switch start contact. Like the headlight relays, which greatly reduce the current through the ageing light switch contacts to extend its life, the starter motor solenoid relay greatly reduces the current through the ageing ignition switch start contacts to extend its life.

2CV Battery Keeps Going Flat?

Are you experiencing a flattening battery in your 2CV, perhaps three or four weeks after its last run, when the battery won't start the engine? This will usually be caused by a constant low current drain on the battery, resulting in the battery being slowly discharged.

This article also applies in principle to other vehicles which do not have an "Accessories" position on the ignition switch.



Fig. 4-6 What's that? Yeah, the battery. Can you give me a push?

Some background:

When the 2CV left the factory at Day 1, there was *zero* current being drawn from the battery when the vehicle's electrical equipment was switched off. Not even a microamp.

Moving on to today, consider a 2CV with added devices such as a radio, CD player, UHF CB radio, etc. As the 2CV doesn't have an accessories position on the ignition switch, it's common practice to wire added devices *directly* to the battery supply wiring, each device fitted with its own inline fuse, such as shown in Fig. 4-7 at right.



Fig. 4-7

For information, if an added device is wired to the 2CV battery via the ignition switch, the ignition switch will have to be turned on to operate the device. However, if the engine is not running at the time, that would be a *very bad idea* because the ignition coil will overheat and potentially be destroyed in a short time, so it's common practice to wire added devices *directly* to the battery supply, bypassing the ignition switch.

Added devices may draw a standby current when switched "off":

When an added device, wired directly to the battery supply, is switched to "off" at its on-off switch, it may still draw a small standby current from the battery, and it's this standby current which is the cause of the battery being flattened! It's not a fault within the device. It's how it was designed and how it operates.

Please explain!

Say your vehicle has a radio fitted, perhaps similar to Fig. 4-8 at right. What's that? Yeah, Retro. Say it draws a standby current of 50 milliamps (0.05 amps) when switched off. (Ok, but it's only a small current so it won't be of any concern...).



Fig. 4-8

Let's calculate how many amp-hours the radio draws from the battery over a four-week period when the 2CV is not being used. The number of hours in four weeks = 24 (hours per day) x 7 (days per week) x 4 (weeks) = 672 hours, so the amp-hours drawn from the battery by the radio = 0.05 (amps) x 672 (hours) = **33.6 amp-hours**. Ok. And the point is...? If the battery in your 2CV is rated at 45 amp-hours, *75 per cent* of its capacity has been consumed by the radio's standby current over the four-week period, so at that moment, the battery is clearly in a *deeply* discharged state and is *most unlikely* to start the engine! Further, if additional devices drawing standby currents are also fitted, the battery will be discharged even quicker.

As a comparison, consider the amp-hours taken from the battery to start the engine. The Citroen repair manual states on page 135 that the 2CV starter motor draws 150 amps during startup. Say it takes three seconds to start the engine. With 3600 seconds in an hour, 3 seconds = 3 / 3600 = 0.00083 hours. The amp-hours drawn from the battery to start the engine = 150 (amps) x 0.00083 (hours) = **0.124 amp-hours**, a smidgeon of the battery's total capacity.

Let's compare the two figures:

To gather a sense of perspective on these numbers, the amp-hours consumed by the radio's standby current over the four-week period is equivalent to 33.6 / 0.124 = **270, yes 270** engine starts! No wonder the battery won't start the engine!

Battery Types:

Starting batteries: Vehicle starting batteries are *designed* to be *shallow* discharged during engine startup, then *immediately* recharged (topped up) over the following 10-15 minutes of driving. Starting batteries do not like to be deeply discharged, and doing so is likely to result in rapid failure of the battery. Further, starting batteries don't like to be left in a discharged state for any length of time before being recharged. It reduces their storage capacity and working life because of promotion of sulphation at the plates.

Deep-Cycle Batteries: On the other hand, deep-cycle batteries, such as those used in caravans, are designed to be more tolerant of being deeply discharged and remaining in a discharged state for extended periods before being recharged.

Of course, such conditions are never ideal for deep-cycle batteries either, but at least they have a better chance of surviving such conditions than starting batteries. A fair question: As deep-cycle batteries are more tolerant to such adverse conditions, why then don't we use deep-cycle batteries as starting batteries? The reason is because deep cycle batteries can't supply the high *peak* current required (*just* before the starter motor starts to turn) or the high *average* current required (while the starter motor is turning) because the deep-cycle battery's internal resistance is too great, a consequence of its design trade-offs. The typical *average* current drawn by a starter motor is in the 200 to 300 amp range (2.4KW to 3.6KW), while the *peak* current is usually 2-3 times the *average* current. Deep-cycle batteries can't supply these currents *and were never designed to do so*.

Finding the cause of the flattening battery:

We'll run some tests in two stages to find out what is causing the current drain on the battery, resulting in the battery being flattened.

Is there a current drain on the battery?

Whaaaaaat? Current drain? What current drain? Everything is turned off!

Firstly, turn off all *switched* electrical equipment in the vehicle. Now we'll check for current drain *at the battery*. To do this, disconnect **all** wiring connections from the battery *negative* post, then gather your multimeter, such as shown in Fig. 4-9 at right. Select the *DC Amps* setting (*not* the separate high-current 10A range). Then connect the multimeter negative lead to the battery negative post and the multimeter positive lead, in turn, to each connection terminal disconnected from the negative post. Record the multimeter reading for each connection terminal.



Fig. 4-9

Q1. Does the multimeter show a current flow at one or more connection terminals?

No. If the multimeter shows zero current flow at each connection terminal, then the flattening of the battery is not caused by an external current drain on the battery, *on the basis* that the vehicle's battery charging system is operating correctly. To check the charging system, reconnect all wiring connections at the battery negative post and start the engine (assuming the battery has been recharged). Set the multimeter to the *DC Volts* setting and measure the DC voltage *at the battery posts* after a couple of minutes of idling. When the engine speed is increased to around 2500 RPM, the battery voltage should be at least 14.2V, confirming the vehicle's charging system is operating correctly.

Turn off the engine. The flattening of the battery is being caused by an *internal* discharge *within* the battery itself, and there's nothing that can be done to save the battery. It will need to be replaced. Over and out. *Adieu*.

Yes, current is flowing at one or more connection terminals. No matter *how small* the measured current is, current is indeed being drawn from the battery and *will be the reason* why the battery is being slowly discharged and flattened. Let's find out the cause.

What is causing the current drain at the battery?

The battery current measured by the multimeter will be caused by either *an added device* connected to the electrical system, or by *a fault* within the electrical system itself. (Although not applicable to the 2CV, classic and older vehicles fitted with an electric (12V) clock will also have a small but constant current drain from the battery.)

To determine if the current drain is caused by an added device or a fault, *disconnect all added devices* from the electrical system by *removing their 12V supply connections* by removing their fuses (they are fused, aren't they??!!), then after selecting the *DC Amps* range on the multimeter, repeat the multimeter test and recheck for current flow in the connection terminals at the battery.

Q2. Does the multimeter show a current flow at one or more connection terminals?

No. If the multimeter shows *zero* current flow at each connection terminal, then the vehicle's electrical system is operating correctly, and the current flow previously measured by the multimeter is caused *solely by the standby currents of the added devices*. By re-connecting each added device in turn to the 12V supply by refitting its fuse, we can measure and record the standby currents of the devices. This will identify the added device(s) causing the current drain and the flattening of the battery.

Yes, current is flowing at one or more connection terminals. If the multimeter test shows that *current is being drawn* at one (or more) of the connection terminals *while all the added devices are disconnected* from the 12V supply, then *the vehicle's electrical system is faulty* and causing the current drain. The fault will need to be diagnosed and corrected.

Diagnostic Flowchart:

A flowchart of the above actions, results and outcomes is shown on the following page.

Conclusion?

If the battery current drain is due to an *added device*, there's no solution except to replace the device with one which doesn't have a standby current! The standby current is intrinsic to the device. No fault found!

In the meantime, to stop the battery being flattened by added devices when the vehicle is not being used, disconnect all wiring at the battery *negative* post.

If the battery current drain is due to a *fault within the vehicle's electrical system*, it should be diagnosed and corrected as the first priority. There should be *zero* current drawn from the battery by the vehicle's electrical system itself.

Better solution?

A better long-term solution to deal with the standby currents of added devices is to fit a battery isolator, such as shown in Fig. 4-10 at right, to the *negative* post of the battery, and isolate the battery when the vehicle is not being used. No more flat batteries!

The isolator also provides a quick and convenient way to disconnect the battery while doing work under the bonnet or behind the instrument panel. Win-win!



Fig. 4-10

Flowchart to Determine Cause of Flattening Battery

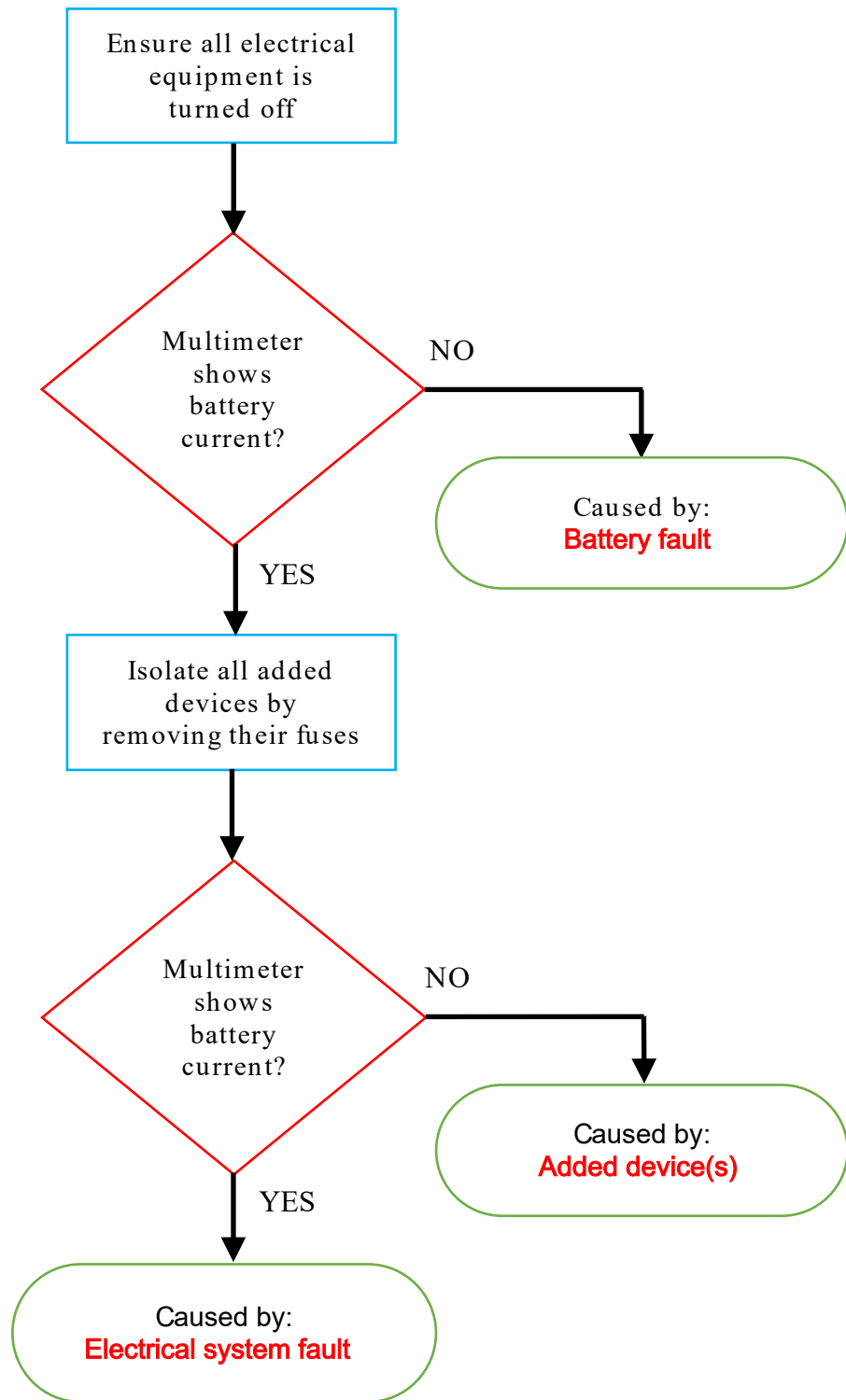

Preventing the engine from starting while cranking:

Should the need arise to turn over (crank) the engine without the engine starting, such as during diagnostic steps, the easiest, fastest and most fundamental method is to disable the production of sparks at the spark plugs. This is readily done by disconnecting the wire connected to the “+” terminal of the ignition coil. This wire will come from either the ignition switch (if points ignition is fitted) or the electronic ignition unit (if electronic ignition is fitted).

Crimped vs Soldered Connections:

A correctly crimped terminal creates a metal-to-metal colloidal bond at the surfaces between the wire and the terminal. If done correctly, no void (space) remains between the strands of the wire and between the wire and the crimp, and the two separate metals are cold forged as one. This ensures very low resistance, mechanically strong and long-life connections. This is the preferred joining mechanism.

If we were to use solder to join the wire to the crimp, the current flowing must pass through the solder, and the resistivity of 63/37 solder is around ten times the resistivity of copper, exacerbating the vehicle’s wiring resistances! Remember, series resistances are additive.

As another point of “comfort”, consider that the aerospace and aviation industries have been using crimped connections for many decades! The AMP Corporation developed (invented) crimped or solderless connections during the Second World War as a way of achieving much greater reliability, quality and consistency of electrical connections when compared to soldered connections.

Re crimped connections. Achieving a high quality crimped connection requires (1) a good quality crimping tool; (2) a correctly-adjusted crimping tool; (3) professional-quality crimp terminals and (4) correct usage by the operator! Poorly designed or manufactured crimping tools and poor quality crimp terminals abound in our cheaper hardware stores, and if these are used, the result can be an abject failure, after which the blame is usually passed onto the crimp terminals as being the cause of the problem, otherwise the bad connections may stay hidden until they start to impact on the operation and reliability of the vehicle.

A point to note:

One is usually unable to remove a crimped terminal by hand from a wire if it has been crimped correctly! Have a practice run. Test every crimp in this manner to confirm its integrity before putting it to use. If the crimp comes off the wire, *something* is very wrong! (Poorly adjusted crimping tool? Incorrect operator technique? Bad crimps?)

In summary, the long-term success and trouble-free operation of your wiring work depends primarily on the quality of the crimping tool and crimp terminals used.

High quality crimping tool recommended by the writer:

Narva Professional Ratchet Crimping Kit 56513. Shown here: [Professional Crimper](#)

This crimper has four interchangeable dies (heads) for crimping a range of terminal types and sizes.

Refer to the writer’s article, **2CV Workshop** for more information on crimping, crimps and crimping tools.

General-Purpose 12-Volt Relays:

Relays conveniently enable the high current drawn by, e.g., the high-beam headlights, to be supplied by the relay and not by the light switch, greatly extending the life of the light switch. The light switch is used to operate the relay only. Relay pin designators are shown when looking directly at the relay pins (which is a universal standard).

1. NARVA relay: 40-amp, 4-pin, **normally open contact**. Part number 68004.

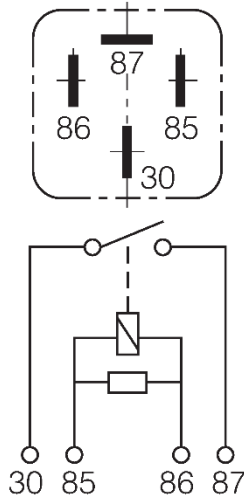

- Pin 30: To battery
- Pin 87: To device being operated
- Pin 85: To ground
- Pin 86: From on-off switch

This relay takes the place of an **on-off** switch. Can be used to switch high current circuits like light circuits, ignition circuit, starting circuit, voltage regulator circuit, etc to carry heavier load currents or to minimise circuit resistances.

2. NARVA relay: 40-amp, 5-pin, **normally open contact**. Part number 68028.

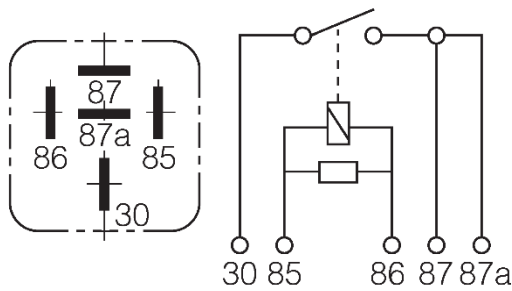

- Pin 30: To battery
- Pins 87 and 87a: To devices being operated.
- Pin 85: To ground
- Pin 86: From on-off switch

This relay takes the place of an **on-off** switch. Can be used to switch high current circuits like lighting circuits, ignition circuit, starting circuit, voltage regulator circuit, etc to minimise circuit resistances or to carry heavier load currents. Conveniently provides two output terminals to connect to two loads, such as two high-beam or two low-beam headlights, saving a wiring junction.

3. NARVA relay: 40-amp, 5-pin, **change-over contacts**. Part number 68044.

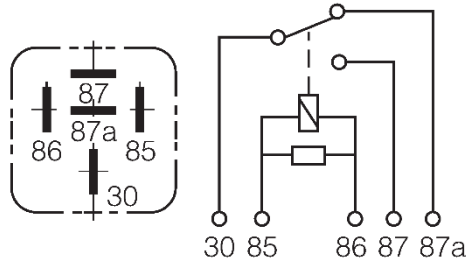

Pin 30: To battery

Pins 87 and 87a: To devices being operated.

Pin 85: To ground

Pin 86: From on-off switch

This relay takes the place of a **changeover** switch, where connection is made to one circuit or the other. When the relay is de-energised, pin 87a is active. When the relay is energised, pin 87 is active.

4. NARVA 5-pin relay connector **socket**. Part number 68084.

Use this to connect the wiring to the relay. Suits 4-pin and 5-pin relays.

Replacement 3-Pin Electronic Flasher Unit:



NARVA Electronic Flasher unit. Part number 68213.

This 3-pin, 2CV-compatible, plug-in replacement flasher unit is not a thermal-type flasher, so is not load-sensitive, meaning its flash rate is independent of the indicator light wattage. It can operate up to ten 21W globes. It has a pilot light function which operates the instrument panel flasher warning light.

The typical (generic) wiring diagram for the flasher unit is shown following.

Typical Wiring Diagram:

Shows the generic electrical connections between the battery, the three-pin flasher unit, the turn indicator switch the front and rear turn indicator globes and the instrument panel indicator warning light.

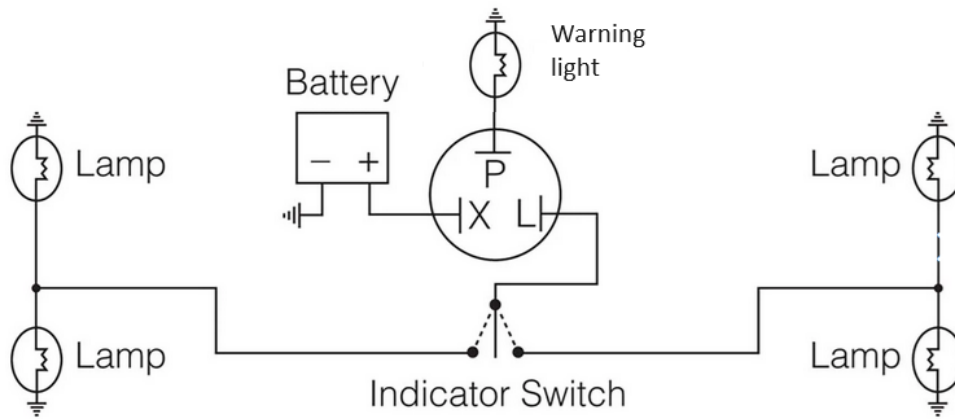

Flasher Unit Pinout (looking directly at the pins):

- X: Connects to +12V via the ignition switch.
- L: Connects to the turn indicator switch.
- P: Connects to the pilot (warning) light on the instrument panel.

Disclaimer: The writer has no association with Brown and Watson International or NARVA.

SPARK PLUGS FOR THE 2CV

The Owner's Manual for the 1987 2CV specifies the following spark plugs may be used:

- AC (ACDelco) 42F
- Bosch W225 T1
- Bosch W5A
- Eyquem 755
- Champion L85
- Marchal 35
- Marelli CW7N
- Firestone F32P

The Haynes Manual specifies the Champion L82C, which is an equivalent to the above plugs. The NGK B6HS is also an equivalent to the above plugs.

Some Electrical Parts used by the writer:

These are offered as suggestions only. Available from various suppliers.

Ignition coil. Burton PN A1.2321 or Der Franzose PN 14311. These are resin-filled.

Alternator brushes: Der Franzose: Search for "*generator brush*". Select to suit Iskra, Ducellier or Valeo alternator as fitted. Burton: Search for "*brushes alternator*".

Starter motor brushes: Der Franzose: Search for "*starter brush*". Select to suit Iskra, Ducellier, Femsa or Paris-Rhone starter motor as fitted. Burton: Search for "*brushes starter motor*".

2CV Light Switch (new): Burton PN A1.6521 or Der Franzose PN 14483.

Bosch RE57 voltage regulator. (Available on ebay, some auto-parts suppliers, etc).

5. ENGINE

Engine Static Timing Marks:

The first step in setting the engine ignition timing is to set the static timing. Insert a **6 mm** steel pin or drill through the dedicated opening in the engine block per Fig. 5-1 below and continue it through into the dedicated opening in the flywheel, after turning the crankshaft to the required position. In this position, the crankshaft has been set to 8° before top dead centre (BTDC), which is the crankshaft's static timing position.

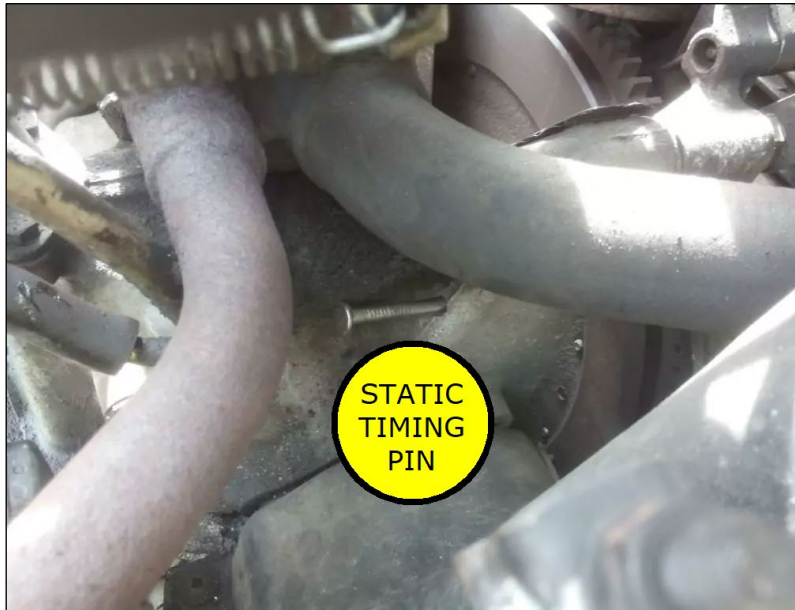

Fig. 5-1

With the flywheel locked in this position with the pin, paint a white mark shown at “b” in Fig. 5-2 below on the ring gear tooth nearest the housing, as shown, and a white mark shown at “a” on the housing at a position *in line* with the mark at “b”. **Be aware of parallax error – note and record your viewing position!**

Remove the timing pin from the engine

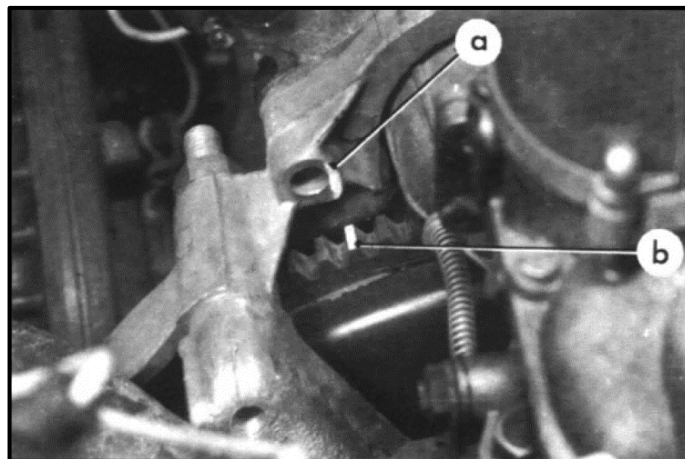

Fig. 5-2

The two marks facilitate the use of a strobe timing light to set the engine dynamic timing to 8° BTDC at idle speed (800 – 850 RPM). When using the strobe timing light, the ignition timing is adjusted so the two white marks are in line as shown in Fig. 5-2. The white marks may fade over time, so repeat the above when necessary to re-establish the two timing marks.

Rear Engine-Gearbox Mount:



Fig. 5-3 Rear Mount

Check the orientation of the rear engine/gearbox mount in your 2CV. See Fig. 5-3 at left and Fig. 5-4 below. When looking from the side of the rear mount per Fig. 5-3, the rubber thickness with dimension *A* may be a few millimetres greater than the rubber thickness with dimension *B*.

If the rear mount is orientated (it can fit either way) so the side with **dimension A is facing rearward, the mount is correctly installed.** However, if the side with **dimension A is facing forward, it's incorrectly installed.**

Why is this important? If the side with dimension *A* is facing forward, the metal plate in the mount, which supports the rear end of the gearbox, will be positioned a few millimetres further to the rear.

This will cause the engine/gearbox to be positioned that few millimetres **further to the rear, reducing the extent** to which the front engine metal mounting brackets overlap the top faces of the front rubber engine mounts.

In a nutshell? There is no adjustment flexibility with the rear mount. It absolutely pre-determines the position of the engine-gearbox in the vehicle! On the other hand, the front mounts do have positioning flexibility. With the rear mount fitted as described, the engine-gearbox will be positioned as far forward as possible.

Those few millimetres of additional overlap at the front mounts are so very much safer than a few millimetres of less overlap!

In summary, we want the side with **dimension A facing to the rear** to maximise the overlap at the front mounts and thus our safety.

Reversing the Rear Engine Mount:

If the rear engine mount is fitted the incorrect way, i.e., with the dimension *A* side facing forward, proceed as follows to reverse it. Again, easier to demonstrate than write about it.

- a. Remove the grille and fan.
- b. Inside the bottom of the fan cowling, unscrew the four nuts (on the front engine mount studs) by say four turns.
- c. Remove the exhaust clamp and rear exhaust pipe fitted to the **outlet** pipe of the crossbox.

- d. Unscrew the two long rear gearbox bolts at the rear mount by 10 mm. The bolts are shown near the centre of Fig. 5-4.
- e. Taking hold of the front exhaust manifold pipes, drag the engine forward as far as it



Fig. 5-4 Rear Mount

will go (several millimetres at best), applying a little upwards lift to the engine. Use a left-right wriggle action to assist.

f. Jack up the **gearbox** until the two long upper rear gearbox bolts have lifted clear of the rear mount.

g. Remove, reverse and replace the rear mount so the side with dimension B is facing towards the gearbox.

h. Lower the jack and allow the two long bolts to settle back into the slots in the rear mount, ensuring both washers remain on the bolt head side of the mounting bracket as in Fig. 5-4.

- i. Jack up the **engine** a little to take the weight off the front engine mounts.
- j. Tighten the two long gearbox bolts, adjusting/wriggling the engine/gearbox positioning as necessary. This is the new position for the engine/gearbox.
- k. Safety check. To maximise safety, **ensure the front rubber engine mounts do not overhang the rear edge of the cross-member on which they sit**. If they do, loosen the bolts securing the engine mounts to the cross-member, move the mounts forward as necessary **but no further**, then tighten the bolts.
- l. Lower the jack, allowing the engine/gearbox to rest on the front engine mounts.
- m. Tighten the four nuts on the front engine mount studs inside the fan cowling.
- n. Reconnect the rear exhaust pipe to the crossbox outlet pipe using the exhaust clamp. If necessary, adjust the under-vehicle exhaust system mounting bolts and fittings to allow the rear exhaust pipe to correctly fit to the crossbox outlet pipe without any stresses or alignment errors.
- o. Inspect all exhaust system fittings from the engine exhaust manifolds to the rear tail pipe. Ensure they are correctly and optimally positioned, joined and secured without air leaks.
- p. Refit the fan and the grille.

At this point, the front engine mounting brackets should have been given maximum-possible overlap with the front engine mounts, and the front mounts are fully resting on the chassis cross-member, maximising safety. It's a once-only task. All done.

Engine-Gearbox Mounts:

Fig. 5-5 below shows the engine-gearbox three-point mounting arrangements. The two larger items at lower left are the front rubber engine mounts which are fitted to the front chassis cross-member.

The brackets above them are the engine-attached metal mounting brackets which are supported by the engine mounts. The item at upper right is the rear gearbox mount.

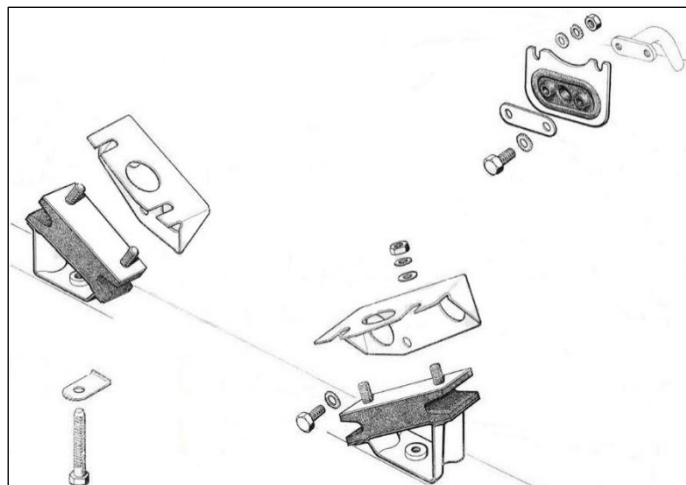

Fig. 5-5 The 3-point 2CV Engine-Gearbox Mounts

Banjo Bolts:

Fig. 5-6 at right shows the engine banjo bolts (oil union bolts). The bolt on the left has a single 2 mm diameter hole where shown and is fitted to the crankcase to secure an oil coupling which feeds engine oil for lubrication to the two cylinder heads via metal tubes. The oil couplings on the other ends of the tubes are fitted to the cylinder heads with two of the banjo bolts shown on the right which have two 0.7 mm diameter holes where shown. Do not mix up the positions of these bolts as the orifices control the oil flow rates and pressures. Clean the bolts with compressed air before fitting.

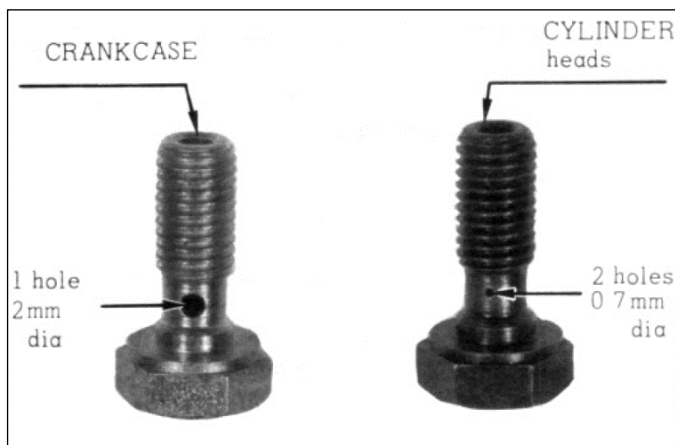

Fig. 5-6 Citroen 2CV Banjo Bolts

Operation:

The banjo bolt and its coupling form a clever type of hydraulic connection which provides a non-rigid, convenient sealed fluid path between say a hydraulic hose and a fixture. In the 2CV, the banjo bolt and coupling fitted to the crankcase takes engine oil to the cylinder heads via metal oil tubes. Fig. 5-7 below shows a banjo bolt, Fig. 5-8 below shows a coupling with the copper seals, designed to be fitted with a rubber hose, and Fig. 5-9 below shows an assembled banjo bolt, coupling and copper seals, ready to be mounted to some fixture for connecting to a threaded hose fitting. (The parts below are not 2CV parts. They are representative only.)



Fig. 5-7



Fig. 5-8



Fig. 5-9

Cleaning the air ways in the Oil Cooler:

Remove the engine cooling fan and spray brake cleaner into the front face of the oil cooler, then gently apply compressed air from the rear face to remove any trapped material. Repeat until visually clear. A work light can assist here.

2CV Engine Rebuild Videos:

The Burton Car Company has a three-part video of an hour's duration showing the steps in rebuilding a 2CV engine. The webpage also lists the replacement parts required, along with the Burton part numbers.

The videos are available at:

<https://www.burton2cvparts.com/en/blog/post/2cv-engine-rebuild>

2CV Engine Case Internals:



2CV Engine Cooling:

The cooling of the 2CV engine is achieved by directing high velocity air, driven by the engine fan, through cowlings (air ducts and channels) to direct the air flow through the cooling fins

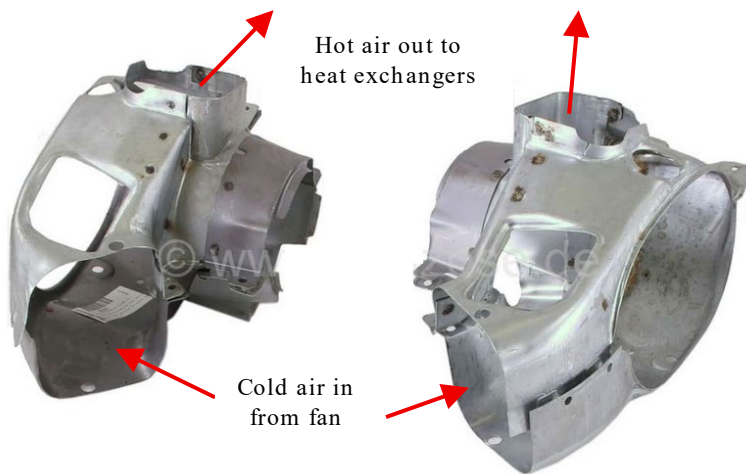

on the cylinders and heads. The 2CV also has an oil cooler which looks like a small radiator element. It too receives high velocity air from the engine fan. The cooling of the engine cylinders, heads and oil by the engine fan air flow provides the cooling for the 2CV engine. Earlier 2CVs used metal cowlings of the type shown in the photo at left. These wrap around the cylinders and heads to direct the air flow through the finned surfaces.

Because there is no closed-loop temperature-control system similar to the thermostat in a water-cooled engine, the 2CV engine operating temperature will change in response to two key parameters: engine loading (amount of fuel burnt) and the ambient temperature.

2CV Composite Engine Cowlings:

Some later 2CVs used cowlings made from a black-coloured material which appears to be a composite of bitumen, rubber and fibre. Cowlings made from the composite material provide two benefits over metal cowlings:

1. The composite material provides a layer of thermal insulation around the engine cylinders and heads, thereby reducing the heat loss from the engine and raising the engine's running temperature. This is a definite advantage in countries with a cool/cold climate, for if standard metal cowlings were used, the heat loss may be great enough to prevent the engine from reaching its optimum operating temperature. (It will forever be a "cold" engine.)
2. The composite material acts as an acoustic noise barrier around the cylinders and heads, reducing engine noise.

And the downside? In Australia, our summer temperatures can surpass the temperatures experienced in many other countries. 2CVs with composite cowlings which have been brought into Australia will experience elevated running temperatures in our summer months due to the thermal insulation provided by the composite material. This is not ideal for maximising the life of the 2CV engine.

The writer's recommendation? If your 2CV is fitted with composite cowlings, replace them with metal cowlings per the photo above. This will lower the engine's operating temperature to a range more commensurate with our climate and your engine will be much happier.

The trade-off is that the engine noise level will be increased slightly, but as we know with the 2CV, there's some chance it may never be noticed! (What noise?)

Some Parts used by the writer:

These are offered as suggestions only. Available from various suppliers.

Rebuilt engine 602cc. Burton PN A1.4305 or Der Franzose PN 10063.

Rebuilt engine 652cc. Burton PN A1.4309. (This is a popular upgrade for the 2CV.)

Fan belt (V-belt). Burton PN A1.2311 or Der Franzose PN 10008.

2 x engine mounts. Burton PN A1.5915 or Der Franzose PN 10049.

Oil breather. Der Franzose PN 10031.

Oil breather gasket. Der Franzose PN 10014.

Sump drain plug with magnet. Burton PN A1.4346.

Sump drain plug copper gasket. Burton PN A1.4347 or Der Franzose PN 10001.

Foam rubber air filter element. Burton PN A1.2501.

2 x inlet manifold gaskets. Burton PN A1.5323 or Der Franzose PN 10408.

2 x exhaust manifold gaskets. Burton PN A1.5322 or Der Franzose PN 10340.

4 x inlet manifold bolts. Burton PN A5.0734 or Der Franzose PN 10639.

4 x copper plated exhaust manifold nuts. Burton PN A5.0709 or Der Franzose PN 20139.

Rubber hose from oil breather to air filter housing. Burton PN A1.4349 or Der Franzose PN 10113.

Rubber hose from oil breather to dipstick tube. Burton PN A1.4459 or Der Franzose PN 10232. (Doesn't use clamps. Friction fit only.) If necessary, slightly bend the metal tubes to achieve alignment.

Spark Plug leads. Der Franzose PN 14306. (Original Citroen Bougicord).

Oil Filter. Purflux LS131. (The original and best filter). Available locally from Spares Box at: <https://www.sparesbox.com.au/part/purflux-oil-filter-ls131>.

Heater tube set. Burton PN A1.8903. Confirm these match your car's requirements.

Cooling air discharge tubes. 2 x short heater tubes for discharge of engine cooling air via the guards. Burton PN A1.8911. Fit a 6 mm cable tie on heat exchanger end to hold the tubes in place.

6. LIST OF ARTICLES BY THE WRITER

The articles written by the writer, listed below, may be freely downloaded from either of the following club websites by clicking on the adjacent links and locating the articles. Both websites maintain the latest revisions of the articles. Before using the articles, please ensure the latest revisions are being used, as the articles are updated on an as-required basis by the writer and given new revision numbers.

Citroen Classic Owners' Club of Australia: [Technical Articles](#)

Citroen Car Club of Victoria: [Tech Tips](#)

1. 2CV 40-Litre Fuel Tank
2. 2CV API GL-4 Gearbox Oil
3. 2CV Battery Charging Circuit
4. 2CV Battery Problems Solved
5. 2CV Brake Saga
6. 2CV Buyer's Questions
7. 2CV Carburettor Cover Screws
8. 2CV Carburettor Jets and Adjustments
9. 2CV Dim-Dip Headlights
10. 2CV Engine Problems
11. 2CV Fuel Filter
12. 2CV Fuel Gauge and Battery Meter
13. 2CV Gearbox Output Hubs
14. 2CV Gearbox Unwinding Debacle
15. 2CV Handbrake Adjustment
16. 2CV Hard Luck Stories
17. 2CV Headlights and Rear Lights Improvement
18. 2CV Ignition Coil
19. 2CV Knife Edges Replacement
20. 2CV Low Oil Pressure Beeper and Lights On Beeper
21. 2CV Maintenance - Part 1 of 2
22. 2CV Maintenance - Part 2 of 2
23. 2CV Oil Breather
24. 2CV Oils and Maintenance Advice From Burton Car Company
25. 2CV Points Ignition Reinstallation
26. 2CV Roof Rack
27. 2CV Secondary Choke Butterfly Adjustment
28. 2CV Spare Parts to Carry
29. 2CV Valve Clearance Adjustment
30. 2CV Workshop
31. Better Fuel Hose Clamps – **applies to all vehicles**
32. Better UHF CB Car Radio Performance – **applies to all vehicles**
33. Ignition Coil Ballast Resistors – **applies to all vehicles**

FINAL STATEMENT

This article may be updated in the future and assigned a new revision number. Please download the latest revision before using the information in this article.

The *Corrosion and Electrical Systems* section in Electrical Systems is excerpted from an article by Carl Heideman, published in Grassroots Motorsports, February 2005. Used with permission.

My acknowledgement and grateful appreciation is given to Haynes Publishing Group for the electrical wiring diagram from the book, Citroen 2CV Owners Workshop Manual.

My acknowledgement and grateful appreciation is given to the web sites from which photos/drawings/diagrams have been sourced.

If material copyrighted by others has been inadvertently used in this document without permission, then upon receiving advice, the writer will remove the material immediately.

If you have questions about the information in this article, if you find errors or incorrect statements, if you have suggestions for improvement, or should you wish to republish this article in your club magazine, please - contact the writer at: gdennes@gmail.com

The hosting or republishing of this article without the formal consent of the writer is not authorised and will constitute an infringement of Copyright Law.

Copyright © Graeme Dennes 2020, 2026